

DAE Working Paper WP 0315



UNIVERSITY OF
CAMBRIDGE
Department of
Applied Economics

Cross-Border Trade: A Two-Stage Equilibrium Model of the Florence Regulatory Forum Proposals

O. Daxhelet and Y. Smeers

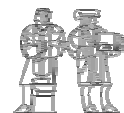

The
Cambridge-MIT
Institute

*Massachusetts Institute of Technology
Center for Energy and
Environmental Policy Research*

CMI Working Paper 22

DAE Working Paper Series



UNIVERSITY OF
CAMBRIDGE
Department of
Applied Economics

**not to be quoted without
permission**



The
Cambridge-MIT
Institute

*Massachusetts Institute of Technology
Center for Energy and
Environmental Policy Research*

CMI Working Paper Series

Cross-Border Trade: A Two-Stage Equilibrium Model of the Florence Regulatory Forum Proposals

O. Daxhelet* Y. Smeers†

July 24, 2002

Abstract

We present a computable model that encompasses several proposals of the “Florence Regulatory Forum”, initiated by the European Commission to deal with cross-border trade. Specifically, the model imbeds both the access to the network and congestion issues analysed by the Forum. Access charges reflect the mechanism devised by the Forum, and congestion at the interconnection is managed through the coordinated auction mechanism recently suggested by the European association of Transmission System Operators. The model allows for various domestic regulation of the national non-eligible market, and different forms of competition in the eligible market. We illustrate this flexibility on a stylised but extensive numerical example with the view of showing that the model behaves properly, and identifying policy issues to be studied in a more realistic case study.

1 Introduction

The restructuring of the electricity sector has now been going on for more than a decade in various regions of the world. The various market designs that emerged from the process testify that the task is not easy. An interesting and relevant question is whether it is possible to integrate power systems organised according to different paradigms into a single electricity market. Integration was the

*Chief Analyst, Electrabel Quantitative Analysis, Louvain-la-Neuve, Belgium.

†Tractebel Professor of Energy Economics, Department of Mathematical Engineering and Center for Operations Research and Econometrics, Université Catholique de Louvain, Louvain-la-Neuve, Belgium.

initial goal of the Council [7] when it set “greater integration, free from barriers to trade” as an objective of the European Community in September 1986. This objective has since been recalled and emphasised in various documents of the European Commission, e.g. [9, 11]. More than a decade of restructuring has certainly changed the European power system, but it is not clear that it has made it any closer to the “real single integrated market” [14] claimed by the European Commission. Similar problems arise on the other side of the Atlantic where integration of different zones into a single market has also been a major objective of FERC’s activity in the year 2001 [29] and in the beginning of 2002 [30]. An intriguing question is whether this integration requires some initial harmonisation or not. FERC seems to have concluded that this is indeed a prerequisite [30]. Europeans maintain that it is not [25] and propose mechanisms whereby the integration of systems organised according to different market paradigms are claimed to be achievable. It is the modelling of these mechanisms of regional power systems organised according to different designs into a single market, that we take up in this paper. Our emphasis is on the European Union and its Internal Electricity Market (IEM).

This work originates in the activities of the so-called “Florence Regulatory Forum”. Initiated by the European Commission in 1998, “The Forum convenes twice a year at the European University Institute near Florence and consists of national regulatory authorities, Member States, European Commission, Transmission System Operators, electricity traders, consumers, network users, and power exchanges. The Forum was set up to discuss issues regarding the creation of a true internal electricity market that are not addressed in the Electricity Directive. The most important issues addressed currently at the Forum concern cross border trade of electricity, in particular the tarification of cross border electricity exchanges and the allocation and management of scarce interconnection capacity” [10]. The results achieved by the Forum on these two issues are summarised in short minutes available on http://europa.eu.int/comm/energy/en/elec_single_market/florence/index_en.html. More technical discussion of this activity can also be found in various reports published by the association of European Transmission System Operators (ETSO, <http://www.ets-net.org>). The work of the Forum also led to new EU legislative proposals [12, 13]. One of these proposals, namely the draft regulation on cross border trade is analysed in Boucher and Smeers [1]. An overview of the lengthy process towards the internal electricity market is given in Smeers [40].

This paper concentrates on the two problems addressed by the Forum, namely access to the network and allocation of interconnection capacities. Like any other question in EU, the treatment of these issues is driven by *subsidiarity*. The principle of *subsidiarity*, which appears in the Maastricht Treaty, “articulates a presumption that the power of EC institutions should be limited to those

functions that cannot be adequately performed by the Member States” [4]. This principle is certainly fully justified if applied in a strict sense. The practice is that it appears to be often biased by political contingencies. Technically or politically difficult questions, for which a solution at the EU level is warranted, are sometimes *left to subsidiarity* because of the difficulty of finding an agreement among Member States. The main IEM legislation of the EU, namely Directive 96/92/EC [8] is a masterpiece in this respect. Hancher [33] calls it “a framework in the loosest sense of the word: its objectives are laid down in very general terminology and moreover, Member States are given a substantial degree of choice in how they are about introducing more competition into their electricity markets. Indeed the margin is so substantial that it would seem possible for the determined anti-market countries to avoid introducing any meaningful degree of competition at all” (see also [32]). The Florence Forum was to overcome some of these deficiencies, particularly those related to cross border trade.

The work of the Forum is also subject to subsidiarity. This implies that a balance should be found between EU-wide and Member States specific solutions in both access to the network and allocation of the interconnection capacities. One could argue that economic analysis provides a relatively clear-cut case in favour of a common EU congestion management system. The absence of a standard market design indeed introduces various market incompleteness that eventually jam the physical market and hence the derived financial market (see Smeers [39] and Boucher and Smeers [1]). The result is that a *real single integrated market* composed of different market designs will only be a fraction of what it could be in a more harmonised structure. This is the reasoning that seems to have recently been adopted in the US [30] where a common market design is now clearly advocated. A strong argument can thus be made that subsidiarity mandates a common congestion management system. Interestingly enough, ETSO concludes differently. In [25] it indeed asserts, but does not justify, that “This goal will be achieved by providing practical market-based mechanisms to manage congestion between regions, while allowing the co-existence and evolution of different market structures within regions”. Coordinated auction [20] is the mechanism proposed for achieving this goal. It is this mechanism that we suppose in this paper.

The need for harmonisation is less compelling for the other problem discussed by the Forum, namely access to the network. First, unlike congestion, this problem is not a matter of market design in the sense that one is not trying to find prices to allocate some restricted capacities. One can indeed conceive a seamless access to the network that is based on sufficiently harmonised but not identical rules among Member States. Subsidiarity therefore suggests but does not mandate that the problem be handled at EU level. This is what the Forum proposed: Member States will adopt common rules but some leeway is allowed

on how they set some parameters appearing in these rules. Needless to say, some distortion of competition will result from the arrangement. But distortions seem unavoidable, whatever the economic sectors, whether among EU Member States or in more federal systems like the US. The relevant question is whether this distortion of competition is significant enough to seriously endanger the goal of the single integrated market. This is the problem that we try to explore in this paper through a computable model.

The paper is organised as follows. Section 2 briefly introduces the outcomes of the Florence Regulatory Forum, which are then elaborated on in more detail in sections 3 and 4. Section 5 provides a modelling framework that tries to capture the essential features of the Forum proposals. This model is a very schematic but it contains many ingredients that allow it to be developed into a more realistic description of the EU power system. In short, the EU is modelled as a set of control areas separated by interconnection capacities. In compliance with the Directive 96/92/EC, and in view of the inconclusive outcome of the Barcelona Council of March 2002, we retain both an eligible and non-eligible (whether legal or *de facto*) market in each control area. Divestiture of capacities by domestic companies took place in the EU, with the result that there are now several generation companies in each Member State. This is modelled too. These producers serve the domestic market and engage in cross border activities. This results in several payments due to the use of the domestic and international networks. Specifically international transactions give rise to two charges. One is a contribution to the fixed charges of foreign networks, and the other is a congestion charge on the interconnection.

Directive 96/92/EC left quite a lot of flexibility to Member States to organise their domestic power systems. This applies to both network cost allocation and congestion management. For the sake of simplicity, this stylised model follows the common wisdom and assumes away congestion in the domestic grid. This simplification allows one to focus attention on the allocation of network costs and congestion at the interconnection. We consider several commonly discussed fixed cost allocation procedures and suppose, because of subsidiarity, that different methods can be implemented in different Member States. Following both ETSO's recommendations and the developments observed on the market, we suppose that access to the interconnection is ruled by an auction that allocates the *transfer capacities* (see section 3 for definition and discussion of transfer capacities) to those that attribute the highest value to it. Auctioning transmission capacities is one of the proposals of the Florence Forum that is currently (and sometimes naively) implemented on interfaces in continental Europe. Co-ordinated auction [20, 26] is the mechanism proposed by the ETSO to allocate transmission capacities while allowing to retain the diversity of organisation of national markets. We therefore model the allocation of transmission capacities

according to this principle. This discussion completes the institutional description of the EU restructured electricity system. Section 6 cast these different elements into a computable model. In this model, and in compliance with the outcome of the Florence Regulatory Forum, the determination of some parameters of the allocation rules is left to Member States. Assuming the network cost allocation parameters, the end result is an equilibrium model that imbeds both cost allocations procedures and the concurrent auction process of transmission capacities. Because market power seems unavoidable in electricity, the model also encompasses different assumptions in this respect, as well as a different form of regulation of the non-eligible market.

Section 7 moves one step further and considers the problem of choosing the cost allocation parameters at Member State level, as a game between national regulators. There is indeed no EU regulator in electricity, and it is unlikely that there will be one, as this would be (opportunistically) argued as an unacceptable violation of subsidiarity. But there is a Committee of European Electricity Regulators, namely the CEER (note that there is no German Regulator and hence the German participation to CEER is through a Member of the administration). One can ideally assume that the members of that Committee behave cooperatively seeking to achieve the common good. Alternatively, the natural interpretation of the absence of a EU regulator is that national regulators behave non cooperatively. We therefore model the actions of the members of CEER as a Nash equilibrium where each regulator selects the fixed cost allocations parameters in a way that maximises the welfare of its own constituency taking the actions of the other regulators as given. We compare this solution to the one where there would be a single EU regulator that maximises the overall welfare of the EU. Because these regulatory actions determine a market between producers and consumers, the overall problem is a two-stage game: regulators decide on the network cost allocation parameters in a first stage taking into account the reaction of the market in the second stage of the game. Section 8 gives numerical results for a stylised example.

The various tests conducted indicate that the model performs as expected on those phenomena that we know well from economic theory. The possible distortion of competition that results from the allocation of the fixed costs of the network shows up as expected and welfare increases when one moves from a non-cooperative to a cooperative equilibrium. But the model also reveals that some allocation methods foreseen by the compensation mechanism do not necessarily perform as expected: they may induce undesired effects. Even though both the compensation methods and allocations of network costs may not influence total welfare much, they drastically influence the allocation of that welfare. Last but not least, the model reveals a close interaction between the access charge and the value of the interconnection. This indicates that these two problems which have

been considered separately by the Florence Forum may be more interdependent than expected.

2 The Outcome of the Florence Regulatory Forum

As indicated above the mandate of the Florence Regulatory Forum is to explore the questions of access to the network and congestion management of the interconnection. We summarise the outcome of this work on the basis of papers published by the organisation of European Transmission System operators (<http://www.etso-net.org>). Briefly speaking, these documents deal with :

a. The elimination of pancaking in access to the network, through a new system of access rules. These are briefly presented in section 3 of this paper on the basis of [17, 23, 31]. In short, the objective is to arrive at a *license plate* system, such as found in the USA and NordPool. In such a system, each agent pays a given fee for connecting to the network. This fee allows this agent to trade with any counter-party connected to the grid. The question faced by ETSO was to find a method for computing this fee in such a way that it recovers the embedded cost of the local network and the cost imposed by some transactions in different parts of the grid. While the rules elaborated by ETSO apply to the whole of the EU, they contain some parameters that are *left to subsidiarity*. Needless to say the choice of these parameters will have an impact on the cost charged to the different agents and hence on the relative competitiveness of generators located in different zones of the *integrated market*. The assessment of this effect is one of the objectives of our computable model.

b. A system of congestion management for allocating interconnection capacities. Many ETSO documents [15, 16, 18, 19, 20, 21, 25, 26, 27, 28] deal with the allocation of interconnection capacities. The notion of transfer capacity and various congestion management methods are discussed in these papers. We rely on the idea of coordinated auction introduced by ETSO in April 2001 [20] and since advocated as the principle that will allow one to retain the current diversity of institutions in the electricity market. A discussion of this claim can be found in Boucher and Smeers [2].

3 Network Costs and Access Charges

The elaboration of conditions for accessing the network constitutes the first subject addressed by the Forum. The principles supposed to rule these conditions are stated in Articles 3 and 4 of the draft regulation [12]. We here discuss their implementation as it results from ETSO's work. The following principles taken from [24] summarise the situation :

1. *“TSOs hosting transits should be compensated for costs associated with the use of new and existing infrastructure”*
2. *“Cost calculations should be standardised, transparent and based on real flows”*
3. *“Exporting and importing TSOs should compensate TSOs hosting transits in proportion to the energy exported and/or imported and based on physical flows”*
4. *“Full infrastructure costs will be considered for inter TSO compensation”*
5. *“The new costs or incomes for TSOs from the compensation mechanisms should be transferred to the domestic transmission tariffs”*
6. *“It is not the role of the compensation mechanisms to provide short or long-term economic signals”*
7. *“Cost for losses should be considered for the inter TSO compensation”*

Principle 1 states that some TSOs incurs costs because of transit. They should be compensated for these costs. This cannot be disputed. Principle 2 is also fully justified. Its second sentence that states that cost should be measured with respect to real flows has a flavour of cost allocation. All ETSO's documents confirm that the whole reasoning of the organisation is in terms of cost allocation. Even though this is probably the only possible operational approach to the problem, one can remark that cost allocation does not comply with the principle of average long run incremental cost stated in article 3.6. of the draft regulation. We do not elaborate any further here on this issue and take it for granted that ETSO's aim is to develop a cost allocation scheme that tries to reflect cost causality. Principle 3 is a simplification (possibly quite justified) with respect to physical realities. It states that the cost due to transit originates in import and/or export. Strictly speaking this is not true as loop flows make it possible for domestic transaction to have an impact on transit costs as defined in article 2 of the draft regulation. This effect is neglected here, which simplifies the problem.

Principle 4 is puzzling. ETSO had in the past [17] developed the concept of horizontal network with the view of identifying this part of the network those cost would capture the costs of transit. The *Horizontal Network* is the “part of the transmission system, which is used to transmit electricity between countries and within the country: it contains the transmission system elements that are influenced significantly by cross-border exchanges”. The *Vertical Network* consists of the local transmission and/or distribution, allowing the access of both the load and the generation to this Horizontal Network. The notion of an horizontal network is somewhat arbitrary from a physical or economic point of view. But it is fully compatible with a cost allocation perspective. ETSO endeavoured to assess the costs of these two parts of the network by conducting systematic load flow computations and measuring the use of the infrastructure due to international flow. The Belgian regulator objected to only relying on the cost of the horizontal network for compensation purposes. The end result is that the “full infrastructure cost” can now be considered. This will definitely enlarge the domain of charges that need to be covered by the compensation mechanism. This has no impact on the structure of our model of ETSO’s proposals. But it has on the domain covered by the parameters of the model.

Principle 5 mandates that TSOs pass these costs to users of the national system. The way this should be done has been the subject of intense discussion in the Florence Regulatory Forum. Recent documents [24] indicate that the issue is not fully settled yet. Principle 6 argues that the compensation mechanism is only driven by accounting considerations without any economic objectives. Interestingly enough, ETSO’s language sometimes refers to location signals and hence expresses economic concerns. Because our model neglects losses; we disregard principle 7 from now on and concentrate on the other points.

Summing up, the idea is that a “compensation for transit will be provided in the form of inter-TSO payments as a result of a future Cross-Border Trade mechanism.” [24]. This inter-TSO payment requires answering three questions namely (a) finding the costs incurred by TSO’s hosting transits, (b) identifying the relative contribution to these costs by exporting and importing TSOs and (c) transposing these costs into national tariffs.

a. The costs incurred by “TSOs hosting transits”. In order to identify these costs, ETSO developed the notion of horizontal network as the part of the grid where flows are significantly affected by transit. The organisation of Transmission Operators then proceeded to estimate the embedded cost of the horizontal network and to allocate a fraction of this cost to transit flows. This process is documented in [16, 17, 22]. It resulted in what was referred to as a compensation fund [22] estimated to an annual 200 Millions Euros. A more

sophisticated approach, to be developed in the future, is hinted in [31]. In this method, each TSO would try to assess the impact of transit on its network costs in Euro/MWh terms. Depending on how this amount is computed the end result could be a Long Run Average Incremental Cost or a more elaborate allocated cost. In the absence of any further information, and taking stock of ETSO's general reasoning, we stick to the cost allocation interpretation in this paper. However, we note in passing without elaborating that the application of Long Run Average Incremental Cost would lead to a model endowed with better mathematical properties.

b. The relative contribution to these costs by exporting and importing TSOs. Quoting the Florence Regulatory Forum [31], “The temporary system proposed by ETSO in September 2001, contains an underlying assumption that all export/import flows of electricity in the EC have an equal effect in terms of transit flows, i.e. contributions to the fund are directly proportionate to measured physical inflows/outflows and programmed exports...”. Taking stock of this implicit assumption, each TSO contributes to the fund according to a priori given coefficients identical for all TSOs. “It has been proposed that the contributions to the fund will be made by TSOs in two parts reflecting different allocation keys: (i) in relation to declared exports, which would be collected through a specific charge imposed only on those operators which have the responsibility for export flows, (ii) in relation to net flows, defined as the countries net flow in export and import directions. Contribution would be collected from consumption (L).” The exact mechanism is stated in section 5.4. As to the future “A more accurate method would be to work out, as accurately as possible and for each Member State, the actual amount and path of transit flows caused by a unit of electricity exported and/or imported from/into the Member State in question. The objective would be to establish for each zone a transit impact coefficient for both exports and imports from that zone. The contribution of each TSO to the compensation fund would then be established on the basis of two elements: the physical export and import flows and the transit impact coefficient”. This extension amounts to a change of allocation rule that can easily be imbedded in our current model. Combined with the Long Run Average Incremental Cost measure of transit costs, these coefficients would lead to a model where each TSO would be charged the Long Run Average Incremental Cost that it implies on the other TSOs. Again, we mention in passing that this model would be endowed with better mathematical properties than the current modelling of average cost pricing.

c. The transposition of these costs in national tariffs and the general structure of these tariffs. This third question has been most contentious.

The controversy is reflected in the two contradictory statements taken from [24]. Consider first the principle that “transmission tariffs shall consist of input and exit charges (G and L) only there shall be no extra tariffs for import, export or transit: a consequence of the previous principle is that import, export and transit tariffs, or fees payable by market players, will be abolished”. This is to be contrasted with “As the result of many compromises, an export fee is included and provides a location signal to a certain degree” [24]. The contradiction between these two statements can be resolved by noting that ETSO wishes to get rid of the export charge by introducing location charges to consumers and generators but has not yet found the way to do so. In the meantime, an export charge will continue to play the role of this location signal. We therefore insert an export charge in our model. Besides this basic controversy on the export charge, considerable divergence remains among Member States on the allocation of these charges between consumers and generators: “Today national transmission tariffs differ widely. Generators in some countries pay a significant G, whereas others pay nothing. Transmission tariffs in most countries are of the postage stamp type, but some others use more cost-reflective models. These differences result in unequal competition conditions and distort the electricity market. Greater harmonisation could help to level the European playing field. It is more important to harmonise G than L, as generators compete on the common market. There is no consensus today within ETSO regarding such harmonisation but two alternatives are under discussion. There are to fix a Europe-wide level for G, or to harmonise charging principles”. We retain for the sake of our model that it is important to be able to model different allocation of network costs into charges to generators (G) and consumers (L). Specifically the capability to computationally assess the distortion of competition that would result from leaving the determination of these charges to subsidiarity is of the essence.

4 Congestion, Transfer Capacities and their Allocation

Congestion cost occurs when an equipment of the grid is used at maximal capacity. Congestion may originate in different phenomena. The simplest most commonly mentioned one is the thermal limit of the lines, but the unavailability of certain services (reactive power or spinning reserve in some region) can also lead to congestion. As indicated in the introduction and consistent with ETSO's work, we essentially neglect congestion in the domestic systems and concentrate on limitations of flows on the interconnection. The Forum suggests that these limitations be ruled through the allocation of *transfer capacities*.

ETSO devoted a lot of attention to the definition and analysis of transfer capacities. The draft regulation also invokes transfer capacities and recommends that they be allocated through market mechanisms. The inadequacy of the notion of transfer capacity is elaborated in Boucher and Smeers [1] and alluded to in several early documents of the organisation. These drawbacks have since also been pointed out in [36].

In April 2001, ETSO introduced a proposal for coordinated auction that relies on a new definition of transmission capacities [20]. It further emphasised this new proposal in various papers published at the occasion of the February 2002 meeting of the Florence Regulatory Forum. The concept is most easily understood by referring to the US notion of flow gate implicitly introduced by Chao and Peck in 1996 [6] and since extensively elaborated (see <http://www.ksg.harvard.edu/hepg/flowgate.htm>). ETSO's proposal is based on two principles: (*i*) one can define the (aggregate) transmission capacity (individual line capacity in the US flow gate interpretation) of the interconnection between two adjacent control areas; (*ii*) using Power distribution factors (PDF) one can associate to each transmission transaction a bundle of uses of these transmission capacities. It is then possible to organise an auction where all market players simultaneously bid for bundles of rights of each transmission capacity. The difference between the April 2001 and ETSO's former auction proposals is twofold. First it is recognised that loop flows mandate that each transmission transaction be decomposed into a bundle of rights on the transmission capacities. Second the bundle of these rights needs to be procured simultaneously by a joint auction on all transmission capacities. With respect to the US flow gate debate a first difference is that ETSO does not find it necessary to introduce a real time market to financially settle imbalances with respect to the forward market. Even though this may be seen as a major flaw, we disregard the issue of a real time market altogether in this paper and concentrate on the sole forward market. A second difference is that ETSO uses aggregate

flow gates instead of the “few commercially significant flow gates” (see the Ruff-Oren correspondence in <http://www.ksg.harvard.edu/hepg/flowgate.htm>). Very much like the assumption that one can limit oneself to a few commercially significant flow gate remains to be proved in the US, ETSO has not yet assessed the feasibility of constructing aggregate flow gates. We shall not get into this question in this paper where we simply assume that ETSO’s proposal is viable, that is: we assume that (i) one can *a priori* compute the transmission capacity of each interconnection in the sense defined by article 6 of the Draft Regulation [12]; (ii) one can allocate these transmission capacities in a forward market without at the same time implementing a real time market where imbalances between the two markets are settled, and (iii) this allocation can be done through a multi-unit auction.

The allocation of transfer capacity through an auction creates revenue for the transmission operators. The exact use of this revenue is not fully determined yet. But several principles can be found in the Forum documents as well as in the Regulation proposal. Specially, the proceeds from the auction cannot create an additional revenue for the TSO; they should be used for goals such as reinforcing the firmness of transmission capacities firm, or the expansion of the network. We do not get into the representation of the use of congestion revenues in this model.

5 A Stylised Model of the EU System

5.1 General Notation

We introduce the following set of notations for the problem description. Let

- $g \in G$ the set of Generators
- $c \in C$ the set of Customers
- $r \in R$ the set of Regions (geographical areas)

The following subsets can easily be understood: we denote by G^r and C^r the subsets of generators and customers located in region r . Because some markets remain captive or are only partially open to competition, we denote by G_c the subset of generators allowed to supply customer c , and by C_g the subset of customers supplied by generator g .

5.2 The Customers

The demand functions of the final consumers are assumed to be linear. They are defined in inverted form

$$p_g^c(q^c) = \alpha^c - \sum_{k \in G_c} \beta_{g,k}^c q_k^c \quad (1)$$

where q^c is the array of variables q_g^c , representing the supply of producer g to customer c . Parameters α and β are non-negative constants.

Relation (1) implies that (a) the supply price to a given customer c could differ according to the supplier, which accounts for product differentiation, and (b) that supply to this customer by any generator could influence the price of all other generators.

In order to derive a utility function for each customer, we consider the (inverted) demand functions to be the first-order derivative of the utility function. This requires the demand system for a given customer to be integrable. This property is satisfied if and only if the matrix of coefficients $\beta_{g,k}^c$ is symmetric with respect to indices g and k . Then the utility function of customer c is given by :

$$U^c(q^c) = \sum_{g \in G^c} \alpha^c q_g^c - \frac{1}{2} \sum_{g,k \in G^c} q_g^c \beta_{g,k}^c q_k^c \quad (2)$$

The amount to be paid by this customer is equal to

$$E^c(q^c) = \sum_{g \in G_c} p_g^c(q^c) q_g^c = \sum_{g \in G^c} \alpha^c q_g^c - \sum_{g,k \in G^c} q_g^c \beta_{g,k}^c q_k^c \quad (3)$$

and its consumer surplus will therefore be given by the quadratic form :

$$CS^c(q^c) = U^c(q^c) - E^c(q^c) = \frac{1}{2} \sum_{g,k \in G^c} q_g^c \beta_{g,k}^c q_k^c \quad (4)$$

We make the usual concavity assumption on the utility function U . The concavity of U implies the concavity of CS .

5.3 The Producer

Let us decompose the generation cost into a fixed, a linear cost and a quadratic cost of its sales to different agents. The generation costs could be described by the function

$$CG_g(q_g) = K_g + \sum_{c \in C_g} v c_g^c q_g^c + \frac{1}{2} \sum_{c,l \in C_g} q_g^c \omega_g^{c,l} q_g^l \quad (5)$$

In addition to these costs, producer g will also have to pay for two *vertical network* access charges for (a) injecting in the local grid (the G-component), and (b) supplying its customers in their respective region (the L-component). Let ag_r and al_r respectively denote the generation and customer charges. Although the principles are that customers themselves should pay for the customer charge al_r , it is equivalent from a modelling perspective to charge it to the producer.

Producer g will also have to pay a possible *cross-border* fee for all exports, and finally a congestion fee if he uses saturated transfer capacities when supplying a given customer. Let x_g^c and τ_g^c be the cross-border fee for exports, and the congestion charge for fully used lines, respectively. These charges (access, cross-border and congestion) are introduced by the current regulation proposal. Then the transmission costs for generator g are

$$CT_g(q_g) = \sum_{c \in C_g} (ag_{r|g \in G^r} + al_{r'|c \in C^{r'}} + x_g^c + \tau_g^c) \times q_g^c \quad (6)$$

where $r|g \in G^r$ denotes the area of generation and $r'|c \in C^{r'}$ the area of delivery for customer c . The revenues of the generator can easily be obtained by the quadratic relation :

$$R_g(q) = \sum_{c \in C_g} p_g^c(q^c) q_g^c = \sum_{c \in C_g} \left(\alpha^c q_g^c - \sum_{k \in G_c} q_g^c \beta_{g,k}^c q_k^c \right) \quad (7)$$

It is important here to note that this relation includes supplies from other producers on all markets. The benefits of generator g can now be stated as :

$$\pi_g(q) = R_g(q) - CG_g(q_g) - CT_g(q_g) \quad (8)$$

5.4 Transmission

ETSO proposal divides the transmission network in a *horizontal* and a *vertical* network. We will use a simplified representation here accounting for intra-regional transmission on the one hand, and cross-border exchanges on the other hand. We assume that both types of transactions impact some costs to the network operator. We assume a simple linear relation for the network cost function. Let this cost function in region r be described by the relation :

$$NC_r(q) = F^r + \sum_{(g,c) \in T_r} nc_{r,g}^c \times (f_{r,g}^c q_g^c) \quad (9)$$

where T_r represents the set of transactions (g, c) which impact on the transmission network in area r , and $f_{r,g}^c$ is the power distribution factor of a given transaction on the network in area r . This distribution factor is equal to one for all transactions implying a local customer and/or generator, but might be smaller for pure transit. We assume that every MWh flowing through region r due to a transaction from g to c entails a cost $nc_{r,g}^c$.

Note that this expression allows one to work with all mechanisms (current and foreseen) envisaged by ETSO for the compensation fund. The network cost can indeed be set fixed or a priori determined, by limiting oneself to the first term of relation (9). A network cost expressed in EUR/MWh is obtained by only using the second term. Our model adopts the more general expression where a variable non linear network cost needs to be paid for by transmission transactions.

The revenues of the network operator (TSO) are twofold. First, the operator in each region collects access charges ag_r and al_r for each generator and customer located in its control area. Second, it obtains from the Cross-Border Trade Compensation Mechanism (ETSO) a share θ_r of the total compensation fund CF collected on all export transactions. Let X represent the set of all cross-border transactions (whatever the concerned areas) and x be the uniform export tax, the revenues of the local TSO are given by:

$$M_r(q) = \sum_{\substack{g \in G^r \\ c \in C_g}} ag_r q_g^c + \sum_{\substack{c \in C^r \\ g \in G_c}} al_r q_g^c + \theta_r \times CF. \quad (10)$$

The Compensation Fund is obtained from the tax on all cross-border transactions :

$$CF = \sum_{g,c} x_g^c q_g^c, \quad \text{with} \quad \begin{cases} x_g^c = x, & \forall (g, c) \in X \\ x_g^c = 0, & \forall (g, c) \notin X \end{cases} \quad (11)$$

where the export tax, x_g^c , is set to zero for intra-regional transactions. Cross-border transactions contribute to the compensation fund via the export tax, as in equation (11). We can think of this expression in two ways, depending

on whether CF or x is be fixed *a priori*. The share θ_r of the compensation fund which is to be recovered by operator r is defined by the following set of relations. We first compute the portion $XTC_r(q)$ of local network costs $NC_r(q)$ which is deemed due to transit. Denoting by I_r and O_r the measured net flows on interconnections of region r in import and export directions, respectively, ETSO [17] proposes two approaches to compute the transit costs:

$$\begin{aligned} \text{A.} \quad XTC_r(q) &= \frac{\text{Min}(I_r; O_r)}{\sum_{c \in C^r} q_g^c + \text{Min}(I_r; O_r)} \times NC_r(q) \\ \text{B.} \quad XTC_r(q) &= \frac{I_r + O_r}{\sum_{c \in C^r} q_g^c + I_r + O_r} \times NC_r(q) \end{aligned} \quad (12)$$

The fraction in the right-hand side of these relations, defines the volume-based portion of network cost which are attributed to transit. In alternative A, this portion is based on transits through the horizontal network of region r , whereas alternative B is based on global Cross-Border exchanges using the horizontal network in this area. The Compensation Fund will be redistributed between TSOs proportionally to their respective “transit” costs $XTC_r(q)$, using the repartition key θ_r defined by :

$$\theta_r = \frac{XTC_r(q)}{\sum_s XTC_s(q)} \quad (13)$$

The profit of the local TSO can now be expressed by the following relation :

$$NP_r(q) = \theta_r \times CF + \sum_{\substack{g \in G^r \\ c \in C_g}} a_{gr} q_g^c + \sum_{\substack{c \in C^r \\ g \in G_c}} a_{lr} q_g^c - \sum_{g,c} n c_{r,g}^e f_{r,g}^c q_g^c - F^r \quad (14)$$

Note that this formulation of the cross-border mechanism, although faithful to the tariff published by ETSO [17], goes beyond the temporary tariff which was actually implemented from March 2002 on. In the latter, the compensation fund CF has been estimated *a priori* at 200 million Euros, the export tax has been fixed *a priori* to 1 Euro per MWh (estimated on past historical net flows – the balance needed to reach the 200 millions being collected through “socialisation in the national tariff of the different countries”: this is not clear from ETSO documents, and has not been modelled here), and only the share $XTC_r(q)$ of network costs accounting for compensation is computed on real flows.

The model presented here allows for several variants of the proposed regulation :

- the costs imputable to transit may be estimated *a priori* (exogenous value, denoted \overline{XTC}_r) or may be the result of actual flows at the equilibrium (endogenous value $XTC_r(q)$),

- the amount required for the compensation fund may be computed *a priori* (denoted \overline{CF} : this is the case in the current ETSO proposal, where the compensation fund has been estimated at 200 Million Euros), or be the result of the collection of export taxes at some predetermined level \bar{x} (for instance one Euro per MWh), or might still be the result of an equilibrium to cover exactly the sum of costs imputable to transit XTC_r .

Any combination of these two choices may be fitted in the model. Mathematically, we may summarise these possible combinations in table 1:

	A priori \overline{XTC}_r	Endogenous $XTC_r(q)$
Fixed Compensation Fund	$\overline{CF} = \sum_{(g,c) \in X} xq_g^c$ $\bar{\theta}_r = \frac{\overline{XTC}_r}{\sum_{r'} \overline{XTC}_{r'}}$ Compensation: $\bar{\theta}_r \times \overline{CF}$	$\overline{CF} = \sum_{(g,c) \in X} xq_g^c$ $\theta_r = \frac{XTC_r(q)}{\sum_{r'} XTC_{r'}(q)}$ Compensation: $\theta_r \times \overline{CF}$
Fixed Export Tax	$CF = \sum_{(g,c) \in X} \bar{x}q_g^c$ $\bar{\theta}_r = \frac{\overline{XTC}_r}{\sum_{r'} \overline{XTC}_{r'}}$ Compensation: $\bar{\theta}_r \times CF$	$CF = \sum_{(g,c) \in X} \bar{x}q_g^c$ $\theta_r = \frac{XTC_r(q)}{\sum_{r'} XTC_{r'}(q)}$ Compensation: $\theta_r \times CF$
Cost-based Compensation Fund	$CF = \sum_{(g,c) \in X} xq_g^c$ $\bar{\theta}_r = \frac{\overline{XTC}_r}{\sum_{r'} \overline{XTC}_{r'}}$ Compensation: $\frac{\overline{XTC}_r}{\bar{\theta}_r} = \bar{\theta}_r \times CF$	$CF = \sum_{(g,c) \in X} xq_g^c$ $\theta_r = \frac{XTC_r(q)}{\sum_{r'} XTC_{r'}(q)}$ Compensation: $XTC_r(q) = \theta_r \times CF$

Table 1: Combinations of Compensations for Transit

6 The Market Equilibrium Problem

Suppose the regulator has decided upon the value of the charge for accessing its local customers. All rules of the markets are then well specified, which allows one to specify a market simulation model. This model is referred to as the *Second-Stage Equilibrium* problem. It is modelled as follows.

We assume the generators are trying to maximise their own profit, possibly subject to regulatory rules on both the captive and eligible markets. We assume that, as soon as two generators are entitled to supply a single customer segment (eligible market), there should be no price regulation and no discrimination in the access charge. On the contrary, for captive customers, only one generator is allowed to supply them. In order to avoid monopolistic prices, one should apply a regulated pricing scheme. In the following, we will successively consider the application of Profit Maximisation, Price Caps, Long Run Incremental Costs, and various types of Fully Distributed Costs. We derive the second-stage equilibrium conditions for every market segment, according to the retained regulation rule.

For each *legal* pair generator-customer (denoted (g, c) and such that $g \in G_c$), we will write a second-stage equilibrium relation emphasising the local access charge (considered as *given* in the second-stage equilibrium). Depending on the regulation, the relation might take several shapes. In some cases it is possible to analytically invert the equilibrium model, obtaining the equilibrium quantities as a function of the access charges, but this is not true in general. To avoid too heavy notations, we adopt the following convention :

$$a_g^c = ag_r | g \in G^r + al_{r'} | c \in G^{r'} \quad (15)$$

In other words, we group in a single variable, a_g^c , the sum of injection charge in the originating region and withdrawal charge in the delivery region. These regions might be the same.

6.1 Competition on the Eligible Market

First consider the case of customers who may be supplied by several competitors, possibly providing differentiated products (reliability, voltage control, interruptions, etc.). Consider equation (1), describing the demand function of customer c for power from generator g .

The differentiation is obtained through matrix β^c . We have mentioned in section 5.2 that this matrix needs be symmetric in order for the welfare function to be computed. Further, if all coefficients $\beta_{g,k}^c$ are identical for each legal pair (g, k) , then there is no differentiation between products. Let us consider the

profit function for generator g . The profit is defined by the revenues of the power sales, minus generation and transmission costs.

$$\begin{aligned} \pi_g(q) &= \sum_{c \in C_g} p_g^c(q^c) q_g^c - \sum_{c \in C_g} (a_g^c + x_g^c + \tau_g^c) \times q_g^c \\ &\quad - \left(K_g + \sum_{c \in C_g} v c_g^c q_g^c + \sum_{c, l \in C_g} q_g^c \omega_g^{c, l} q_g^l \right) \end{aligned} \quad (16)$$

In order for this profit to be maximised, we write the first-order equilibrium conditions on each of the supplied markets. These conditions involve the profit derivatives :

$$\begin{aligned} \forall c \in C_g : \quad \frac{\partial \pi_g}{\partial q_g^c}(q) &= \left(p_g^c(q^c) + \frac{\partial p_g^c}{\partial q_g^c} q_g^c + \sum_{\substack{k \neq g \\ k \in G_c}} \frac{\partial p_g^c}{\partial q_k^c} \frac{\partial q_k^c}{\partial q_g^c} q_g^c \right) \\ &\quad - (a_g^c + x_g^c + \tau_g^c) - \left(v c_g^c + \sum_{l \in C_g} \omega_g^{c, l} q_g^l \right) \end{aligned} \quad (17)$$

Note that some partial derivatives still remain in this expression. This leaves place for modelling different types of market power.

Market power is partially captured through the partial derivative of the price with respect to the generator's own supply, and should be understood as a measure of the generator's awareness of its own impact on market prices. If the generator believes it has no influence on market price, whatever its supplied quantity, then it behaves as a price taker on this market, and this derivative should be zero. When the generator is fully aware of its impact, this derivative should be set to $\beta_{g,g}^c$, which is the "true" derivative of the demand function with respect to this quantity. Here we will tackle market power through parameter $\xi_{g,g}^c$ taking values from zero to one, and such that

$$\frac{\partial p_g^c}{\partial q_g^c} = -\xi_{g,g}^c \beta_{g,g}^c, \quad \xi_{g,g}^c \in [0, 1] \quad (18)$$

Market power also depends on the assumed values of conjectural variation, represented by the cross-derivatives on demand, $\xi_{g,k}^c = \partial q_k^c / \partial q_g^c$. This derivative accounts for the anticipation of the competitor's move after a change in supply from a generator. Setting this value to zero assumes no reaction from competitors. This is the definition of the Cournot equilibrium. Setting the values such that their sum equals -1 leads to a price war, equivalent to the Bertrand equilibrium. Finally, a value of $+1$ represents a collusive equilibrium.

To sum up, market power is captured through two parameters: $\xi_{g,g}^c$ taking values between 0 and $+1$, accounts for generator's awareness of its own influence on price; parameters $\xi_{g,k}^c$ valued between -1 and $+1$ represents a tuning of the type of competition between generators g and k on market c .

The profit first-order derivative should now be rewritten as

$$\begin{aligned} \frac{\partial \pi_g}{\partial q_g^c}(q) &= \alpha^c - \sum_{k \in G_c} \beta_{g,k}^c q_k^c + \left(\sum_{k \in G_c} \xi_{g,k}^c \beta_{g,k}^c \right) q_g^c \\ &\quad - (a_g^c + x_g^c + \tau_g^c) - \left(v_g^c + \sum_{l \in C_g} \omega_g^{c,l} q_g^l \right) \end{aligned} \quad (19)$$

where the inverse demand function $p(q)$ has been fully expanded. Note that we explicitly consider the generator to be *price-taker* with respect to both the local access charge and the export tax. If profit maximisation is the generator's objective, the first-order equilibrium conditions can be stated, in complementarity form, as :

$$\frac{\partial \pi_g}{\partial q_g^c} \leq 0, \quad q_g^c \geq 0, \quad q_g^c \times \frac{\partial \pi_g}{\partial q_g^c} = 0. \quad (20)$$

Reformulating slightly the first of these conditions in order to isolate the (total) access charge a_g^c , we obtain the following relations :

$$\begin{aligned} a_g^c &\geq \alpha^c - x_g^c - \tau_g^c - \sum_{k \in G_c} \beta_{g,k}^c q_k^c - \left(\sum_{k \in G_c} \xi_{g,k}^c \beta_{g,k}^c \right) q_g^c \\ &\quad - v_g^c - \sum_{l \in C_g} \omega_g^{c,l} q_g^l \end{aligned} \quad (21)$$

And this should reduce to an equality when the supplied quantity q_g^c is strictly positive. Remarkably enough, if all customers within a region were left to competition, then this would boil down to a linear system of equations.

6.2 The Captive Market

This section is dedicated to customers which may only be supplied by a single generator. This assumption simplifies the demand system for those customers, since the matrix $\beta_{g,k}^c$ reduces to a single element. Regulatory mechanisms may however be extended to customers supplied by a limited number of generators, subject to some regulation rule. A quick overview of the latter extension is provided in section 6.3.

6.2.1 Profit Maximisation on the Captive Market

In a methodological sense, this is equivalent to competition on an eligible market, where only one generator is allowed to supply the captive customer. The first summation in equation (21) hence reduces to a single term. Further, we may reasonably assume that a captive customer will have a strictly positive consumption, and therefore replace the inequality in the first-order condition

by an equality. This yields the following relation:

$$a_g^c = \alpha^c - x_g^c - \tau_g^c - (1 + \xi_{g,g}^c) \beta_{g,g}^c q_g^c - v_g^c - \sum_{l \in C_g} \omega_g^{c,l} q_g^l \quad (22)$$

6.2.2 Price Cap

Here we replace the profit maximisation relations by a Lagrangian. Assume the regulator imposes the price cannot exceed \bar{p}^c for customer c . The Lagrangian function can be written as:

$$L_g(q, \mu_g^c) = \pi_g(q) + \mu_g^c \times (p_g^c - \bar{p}_g^c) \quad (23)$$

And the first-order condition leads to the following relations :

$$\begin{aligned} q_g^c &\geq 0, & \frac{\partial L_g}{\partial q_g^c} &\leq 0, & q_g^c \times \frac{\partial L_g}{\partial q_g^c} &= 0 \\ \mu_g^c &\geq 0, & p_g^c &\leq \bar{p}_g^c, & \mu_g^c \times (p_g^c - \bar{p}_g^c) &= 0. \end{aligned} \quad (24)$$

Assuming again that captive customers will not have a zero-consumption, the first set of complementarity constraints boils down to the following equation:

$$a_g^c = \alpha^c - x_g^c - \tau_g^c - \beta_{g,g}^c (1 + \xi_{g,g}^c) (q_g^c - \mu_g^c) - \sum_{l \in C_g} \omega_g^{c,l} q_g^l \quad (25)$$

The complementarity constraint on the slack does however remain.

6.2.3 Long-Run Incremental Cost

This is definitely the simplest pricing scheme. By definition, the price is imposed equal to the marginal cost of supplying the customer. This equates the market equilibrium price with the derivative of the generator's cost function. Therefore we obtain the relation :

$$p_g^c(q^c) = a_g^c + x_g^c + \tau_g^c + v_g^c + \sum_{l \in C_g} \omega_g^{c,l} q_g^l \quad (26)$$

from which we immediately derive the inverse demand function for accessing the network:

$$a_g^c = \alpha^c - \beta_{g,g}^c q_g^c - x_g^c - \tau_g^c - v_g^c - \sum_{l \in C_g} \omega_g^{c,l} q_g^l \quad (27)$$

Again we made the assumption that strictly positive quantities may lead to a feasible solution. Such a feasible solution will not be achieved if $\alpha^c < x_g^c + \tau_g^c + v_g^c$, that is, if the cumulated export tax and congestion fee, plus the linear part of the variable production cost, exceed the willingness to pay for the first MWh of this customer.

6.2.4 Fully Distributed Cost

Fully Distributed Costs allow a regulator to identify each source of costs for the generator, and to allocate them between various customers. This is an easy task for access charges, export taxes, congestion fees and linear variable costs. But it is not that simple for fixed cost, and might even get worse for quadratic costs. Looking at the following costs splitting,

$$\begin{aligned} CG_g(q_g) + CT_g(q_g) &= \sum_{c \in C_g} [(a_g^c + \tau_g^c + x_g^c + vc_g^c)q_g^c + \frac{1}{2}\omega_g^{c,c}(q_g^c)^2] \\ &+ K_g + \frac{1}{2} \sum_{\substack{c,l \in C_g \\ c \neq l}} q_g^c \omega_g^{c,l} q_g^l \end{aligned} \quad (28)$$

we may observe that the first sum accounts for all variable costs which can be separately charged to each customer, while the last line represent non-customer related or mixed-customers costs which have to be allocated in some way.

Several allocation rules can be proposed. We will consider here the classical *quantity-based*, *revenue-based* and *cost-proportional* allocation rules.

The pricing rule for regulated customers becomes:

$$p_g^c(q^c) = a_g^c + \tau_g^c + x_g^c + vc_g^c + \frac{1}{2}\omega_g^{c,c}q_g^c + \psi_g^c(q_g) \quad (29)$$

where $\psi_g^c(q_g)$ stands for the contribution to common costs. According to the retained regulatory rule, this share is computed by:

Quantity-based Fully Distributed Costs

$$\psi_g^c(q_g) = \left(K_g + \frac{1}{2} \sum_{c \neq l} q_g^c \omega_g^{c,l} q_g^l \right) \times \frac{1}{\sum_{l \in C_g} q_g^l} \quad (30)$$

Revenue-based Fully Distributed Costs

$$\psi_g^c(q_g) = \left(K_g + \frac{1}{2} \sum_{c \neq l} q_g^c \omega_g^{c,l} q_g^l \right) \times \frac{p_g^c(q^c)}{\sum_{l \in C_g} p_g^l(q^l) \times q_g^l} \quad (31)$$

Cost-Proportional Fully Distributed Costs

$$\psi_g^c(q_g) = \left(K_g + \frac{1}{2} \sum_{c \neq l} q_g^c \omega_g^{c,l} q_g^l \right) \times \frac{[vc_g^c + \frac{1}{2}\omega_g^{c,c}q_g^c]}{\sum_{l \in C_g} [vc_g^l + \frac{1}{2}\omega_g^{l,l}q_g^l] \times q_g^l} \quad (32)$$

These rules lead to non-linear relations between the regional access charges and the equilibrium quantities. Trying to explicit these relations, however, we get the following equations :

Quantity-based Fully Distributed Costs

$$\begin{aligned}
a_g^c &= \alpha^c - \tau_g^c - x_g^c - vc_g^c - (\beta_{g,g}^c q_g^c + \frac{1}{2} \omega_g^{c,c} q_g^c) \\
&\quad - \left(K_g + \frac{1}{2} \sum_{c \neq l} q_g^c \omega_g^{c,l} q_g^l \right) \times \frac{1}{\sum_{l \in C_g} q_g^l} \quad (33)
\end{aligned}$$

Revenue-based Fully Distributed Costs

$$\begin{aligned}
a_g^c &= \alpha^c - \tau_g^c - x_g^c - vc_g^c - (\beta_{g,g}^c q_g^c + \frac{1}{2} \omega_g^{c,c} q_g^c) \\
&\quad - \left(K_g + \frac{1}{2} \sum_{c \neq l} q_g^c \omega_g^{c,l} q_g^l \right) \times \frac{p_g^c(q^c)}{\sum_{l \in C_g} p_g^l(q^l) \times q_g^l} \quad (34)
\end{aligned}$$

Cost-Proportional Fully Distributed Costs

$$\begin{aligned}
a_g^c &= \alpha^c - \tau_g^c - x_g^c - vc_g^c - (\beta_{g,g}^c q_g^c + \frac{1}{2} \omega_g^{c,c} q_g^c) \\
&\quad - \left(K_g + \frac{1}{2} \sum_{c \neq l} q_g^c \omega_g^{c,l} q_g^l \right) \times \frac{[vc_g^c + \frac{1}{2} \omega_g^{c,c} q_g^c]}{\sum_{l \in C_g} [vc_g^l + \frac{1}{2} \omega_g^{l,l} q_g^l] \times q_g^l} \quad (35)
\end{aligned}$$

As can be seen, these expressions rapidly become heavily non-linear, which makes derivatives of such equilibrium conditions very difficult to manipulate.

6.3 Customers with several Regulated Suppliers

In the stylised model described in section 5, we consider in some regions that several local generation companies might be allowed to supply the domestic market, while the latter remains closed to supplies from outside the region. Local regulators may wish to impose some rules on the regional oligopoly. The implementation of these rules is an extension of section 6.2's results. If no regulation is retained, then the situation would be equivalent to the competition depicted for the eligible market, with a restricted number of competitors, hence we will not elaborate any further on this. We focus here on generalisation of price caps, long-run incremental cost and fully distributed costs pricing schemes.

6.3.1 Price Cap

Let c denote the regulated customer segment having at least two possible suppliers. Let \bar{p}_g^c be the regulated maximal price for producer g (we assume that it is the regulator's responsibility to adequately design the possibly different values of the caps). The Lagrangian function for each producer can be written as:

$$\forall g \in G_c : \quad L_g(q, \mu_g^c) = \pi_g(q) + \mu_g^c \times (p_g^c - \bar{p}_g^c) \quad (36)$$

The first-order condition for each generator $g \in G_c$ states :

$$q_g^c \geq 0, \quad \frac{\partial L_g}{\partial q_g^c} \leq 0, \quad q_g^c \times \frac{\partial L_g}{\partial q_g^c} = 0 \quad (37)$$

$$\mu_g^c \geq 0, \quad p_g^c \leq \bar{p}_g^c, \quad \mu_g^c \times (p_g^c - \bar{p}_g^c) = 0. \quad (38)$$

Here we may not assume anymore that deliveries from all allowed generators g to the regulated customer c will be strictly positive. It is therefore necessary to resort to the complementarity formulation of the first-order condition (37). Let σ_g^c denote the slack for this constraint. We now have the following set of conditions:

$$\begin{aligned} a_g^c &= \alpha^c - x_g^c - \tau_g^c - \sum_{l \in C_g} \omega_g^{c,l} q_g^l - \sum_{k \in G_c} \beta_{g,k}^c \left(q_k^c + \xi_{g,k}^c \times (q_g^c - \mu_g^c) \right) + \sigma_g^c \\ \mu_g^c \times (p_g^c - \bar{p}_g^c) &= 0, \\ \sigma_g^c \times q_g^c &= 0, \\ \mu_g^c \geq 0, \quad \sigma_g^c \geq 0, \quad q_g^c \geq 0, \quad 0 \leq p_g^c \leq \bar{p}_g^c. \end{aligned} \quad (39)$$

6.3.2 Long-Run Incremental Cost

Although very improbable while applying an incremental cost regulation, we have to envisage that deliveries may possibly be zero from some generator to the regulated customer. Pricing at long run incremental cost, according to our formulation, is then equivalent, for any $g \in G_c$ to:

$$p_g^c(q^c) \leq a_g^c + x_g^c + \tau_g^c + v_g^c + \sum_{l \in C_g} \omega_g^{c,l} q_g^l, \quad (40)$$

where the inequality should resume to an equality if quantities are strictly positive. Defining the slack variable σ_g^c we obtain the following complementarity system:

$$\begin{aligned} a_g^c &= \alpha_g^c - \sum_{k \in G_c} \beta_{g,k}^c q_k^c - x_g^c - \tau_g^c - v_g^c - \sum_{l \in C_g} \omega_g^{c,l} q_g^l + \sigma_g^c \\ \sigma_g^c \times q_g^c &= 0, \quad \sigma_g^c \geq 0, \quad q_g^c \geq 0. \end{aligned} \quad (41)$$

Here again we observe that feasible solution may only be achieved if the cumulated export tax and congestion fee, plus the linear part of the variable production cost does not exceed the willingness to pay for the first MWh of this customer. The present formulation now allows for zero deliveries from some generators.

6.3.3 Fully Distributed Costs

Here we extend the formulation which was developed in 6.2.4 to the case of several generators, supplying a regulated customer at fully distributed costs. The assumption of strictly positive deliveries does not hold anymore. The equilibrium conditions may hence be rewritten using complementarity. We use the slack variable σ_g^c to establish the pricing rule:

$$\begin{aligned} p_g^c(q^c) &= a_g^c + \tau_g^c + x_g^c + vc_g^c + \frac{1}{2}\omega_g^{c,c}q_g^c + \psi_g^c(q_g) - \sigma_g^c, \\ \sigma_g^c \times q_g^c &= 0, \quad \sigma_g^c \geq 0, \quad q_g^c \geq 0. \end{aligned} \quad (42)$$

where $\psi_g^c(q_g)$ was defined in equations (30) to (32) according to the retained cost distribution paradigm. The equilibrium relations now become:

$$\sigma_g^c \times q_g^c = 0, \quad \sigma_g^c \geq 0, \quad q_g^c \geq 0. \quad (43)$$

Quantity-based Fully Distributed Costs

$$\begin{aligned} a_g^c &= \alpha^c - \tau_g^c - x_g^c - vc_g^c - \left(\frac{1}{2}\omega_g^{c,c}q_g^c + \sum_{k \in G_c} \beta_{g,k}^c q_k^c \right) + \sigma_g^c \\ &- \left(K_g + \frac{1}{2} \sum_{c \neq l} q_g^c \omega_g^{c,l} q_g^l \right) \times \frac{1}{\sum_{l \in C_g} q_g^l} \end{aligned} \quad (44)$$

Revenue-based Fully Distributed Costs

$$\begin{aligned} a_g^c &= \alpha^c - \tau_g^c - x_g^c - vc_g^c - \left(\frac{1}{2}\omega_g^{c,c}q_g^c + \sum_{k \in G_c} \beta_{g,k}^c q_k^c \right) + \sigma_g^c \\ &- \left(K_g + \frac{1}{2} \sum_{c \neq l} q_g^c \omega_g^{c,l} q_g^l \right) \times \frac{p_g^c(q^c)}{\sum_{l \in C_g} p_g^l(q^l) \times q_g^l} \end{aligned} \quad (45)$$

Cost-Proportional Fully Distributed Costs

$$\begin{aligned} a_g^c &= \alpha^c - \tau_g^c - x_g^c - vc_g^c - \left(\frac{1}{2}\omega_g^{c,c}q_g^c + \sum_{k \in G_c} \beta_{g,k}^c q_k^c \right) + \sigma_g^c \\ &- \left(K_g + \frac{1}{2} \sum_{c \neq l} q_g^c \omega_g^{c,l} q_g^l \right) \times \frac{[vc_g^c + \frac{1}{2}\omega_g^{c,c}q_g^c]}{\sum_{l \in C_g} [vc_g^l + \frac{1}{2}\omega_g^{l,l}q_g^l] \times q_g^l} \end{aligned} \quad (46)$$

Note that no solution to this equilibrium problem may be guaranteed. In some cases, the problem might be infeasible: we discuss this topic in section 8 where such case is met.

6.4 The Coordinated Auction of Interconnection Capacities

In this section we define the mechanism which determines the congestion charge τ_g^c for any cross-border transaction $(g, c) \in X$. We define two new parameters. Let $IC_{r,r'}$ denote the interconnection capacity from region r towards region r' ¹. It is important to note however that these capacities *could* be different in one direction or the other. Let also $\phi_{g|r,r'}^c$ denote the fraction of transaction (g, c) flowing through interconnection (r, r') (a power distribution factor in flow gate parlance). For intra-regional transactions, this factor would be zero for each interconnection, and it should be computed *a priori* for inter-regional transactions. Note also that this distribution factor must have symmetric values, that is, $\phi_{g|r,r'}^c = -\phi_{g|r',r}^c$.

We implement the following opportunity cost mechanism for interconnection pricing. The congestion charge for the use of a saturated interconnection is taken equal to the dual variable $\delta_{r,r'}$ of the capacity constraint. Mathematically, this expresses $\forall r \neq r'$ as :

$$\delta_{r,r'} \geq 0, \quad \sum_{(g,c) \in X} q_g^c \phi_{g|r,r'}^c \leq IC_{r,r'}, \quad \left(\sum_{(g,c) \in X} q_g^c \phi_{g|r,r'}^c - IC_{r,r'} \right) \delta_{r,r'} = 0 \quad (47)$$

The latter formulation ensures that the congestion charge $\delta_{r,r'}$ will remain at zero as long as the interconnection from r towards r' does not reach its capacity limit. For any interconnection (r, r') used by a particular transaction (g, c) , the unit contribution to congestion charges is equal to $\delta_{r,r'} \phi_{g|r,r'}^c$. The total congestion charge incurred by this transaction is given by

$$\tau_g^c q_g^c = \left(\sum_{r \neq r'} \delta_{r,r'} \phi_{g|r,r'}^c \right) q_g^c. \quad (48)$$

This mechanism ensures that, at equilibrium, each transaction (g, c) contributing to the saturation of an interconnection capacity will be penalised proportionally to its own flow on the interconnection, while a transaction generating a counterflow on a saturated interconnection would receive a contribution based on the same rule.

¹This transmission capacity can be interpreted as a flow gate in the US sense (see [6] for the initial paper, and <http://www.ksg.harvard.edu/hepg/flowgate.htm> for further discussion).

7 The Regulators' Game

The regulators' game consists of maximising the local welfare $W_r(q)$ by tuning the access charge al_r to their local customers and ag_r to their local generators.

7.1 Regional Welfare

The regional welfare is equal to the sum of benefits of the local agents. Benefits should be understood as *profits* for operators and generators, and *consumer surplus* for final customers.

From the previous definitions, the regional welfare is defined by:

$$W_r(q) = NP_r(q) + \sum_{c \in C^r} CS^c(q^c) + \sum_{g \in G^r} \pi_g(q) \quad (49)$$

The game is as follows. Depending on the customer segment, generators are either left to competition (i.e. profit maximisation in a Cournot game), or subject to a regulation. In each region, the local regulator selects the repartition of access charges in order to maximise the regional welfare. This leads to a Nash equilibrium, constrained by the conditions of the second-stage equilibrium problem.

7.2 The Conditions for the Nash Equilibrium

Let us state the first-stage problem of each regional regulator as follows. Consider the share of network costs imputable to transit, denoted $XTC_r(q)$. It is not clear yet from ETSO proposals how these costs will be determined exactly. As mentioned in section 5.4, at least two proposals can be found in [17]. We implemented both alternatives of equation (12). Whether these costs should be computed *a priori* using estimates of future flows, or dynamically using the model flows at equilibrium, is a user's choice. In both cases, they define the share θ_r of the compensation fund which will be allocated to the regional TSO to cover its transit costs.

The regulator decides on the access charges al_r and ag_r in such a way that (a) the remaining network fixed costs are covered (and hence that the local TSO's profit is equal to zero), and (b) the regional welfare is maximised. Mathematically, the regulator's problem can be stated as:

$$\begin{aligned} \forall r \in R : \quad & \max_{al_r, ag_r} W_r(q) = \sum_{c \in C^r} CS^c(q^c) + \sum_{g \in G^r} \pi_g(q) & (50) \\ \text{s.t.} \quad & \sum_{g \in G^r} ag_r q_g^c + \sum_{c \in C^r} al_r q_c^c \geq NC_r(q) - \theta_r \times CF \end{aligned}$$

Note that the expression of the network operator's profit function $NP_r(q)$ disappeared from the welfare function: since part of its costs are to be covered by the compensation fund, and that the remainder of its costs is to be covered through access charges while maximising the regional welfare, its profit will be zero and may therefore be removed from the objective function.

This problem however has to be solved for every regional regulator, taking the decisions of the other regulators into account. This leads to a Nash equilibrium. Writing the first-order equilibrium conditions for every TSO requires explicit derivatives of regional welfare with respect to the access charge, and this is not always possible. We therefore solve this problem, iterating on successive regional welfare optimisations problems. This is detailed in section 8.

Let us reconsider the *budget constraint* in problem (50). Instead of deciding on two access charge variables al_r and ag_r , the regulator could review his problem as follows: let λ_r represent the share of the remaining costs ($NC_r(q) - \theta_r \times CF$) to be covered through the generator access charge ag_r . Since it has been established that, when maximising the welfare, the budget constraint would hold with equality, then the problem becomes:

$$\max_{\lambda_r} W_r(q) = \sum_{c \in C^r} CS^c(q^c) + \sum_{g \in G^r} \pi_g(q) \quad (51)$$

$$\text{s.t.} \quad ag_r = \frac{\lambda_r}{\sum_{g \in G^r} q_g^c} \times (NC_r(q) - \theta_r \times CF) \quad (52)$$

$$al_r = \frac{1 - \lambda_r}{\sum_{c \in C^r} q_g^c} \times (NC_r(q) - \theta_r \times CF) \quad (53)$$

$$\theta_r = \frac{XTC_r}{\sum_{r'} XTC_{r'}}$$

$$XTC_r = \begin{cases} \text{or} & \frac{\text{Min}(I_r; O_r)}{\text{Min}(I_r; O_r) + \sum_{c \in C^r} q_g^c} \times NC_r(q) \\ & \frac{I_r + O_r}{I_r + O_r + \sum_{c \in C^r} q_g^c} \times NC_r(q) \end{cases}$$

where the denominators in the two fractions are respectively the total regional production and the total regional consumption. With the latter formulation, there is only *one* decision variable for each regulator : λ_r . Iterating on each regulator's problem yields a Nash equilibrium.

8 A Numerical Example

This last section illustrates the flexibility of the model on a stylised example. We consider a four zones region model (two large and two small control areas) and test the impact of several of the features discussed in the preceding section. We show that the model reproduces expected economic known behaviours and raises new questions. We leave the study of some of these questions on a realistic example for further research.

8.1 Data description

We consider a stylised model comprising four regions. Regions 1 and 2 are comparatively small with respect to regions 3 and 4. In each region r , there is one Transmission System Operator (TSO_r), one or two generation companies (Gen_r), and two customer segments ($Elig_r$ is eligible and accessible to each of the four producers, while $Capt_r$ is captive and supplied by the local generator(s) only). The four regions are linked together by interconnection capacities. Note that we here assume two generators serving the non-eligible markets in regions 3 and 4. The situation is sketched in figure 1. Appendix A gives an extensive description of the data. Tables and figures illustrating numerical results are gathered in appendix B.

For the sake of simplicity, the model presented here is limited to one single time period, for instance one single hour. Hence, quantities expressed in [GWh] are equivalent to power in [GW] during the relevant period of time, that is, one hour. On the other hand, fixed costs are also converted from their annual value onto the equivalent value for the relevant period.

8.1.1 Customers Data

Customers are characterised by a linear demand function. This function is calibrated around a reference point, associating a reference demand level q_0^c to a reference price p_0^c , together with a price elasticity ε^c at that point. The reference values are given in table 2.

In order to rebuild the linear demand functions from these parameters, we only need to remember the definition of the price elasticity at the reference point:

$$\varepsilon^c = \frac{p_0}{q_0} \times \frac{\partial q^c}{\partial p^c} \Big|_{(q_0, p_0)} \quad (54)$$

From this equation, we derive the slope of the linear demand function at the

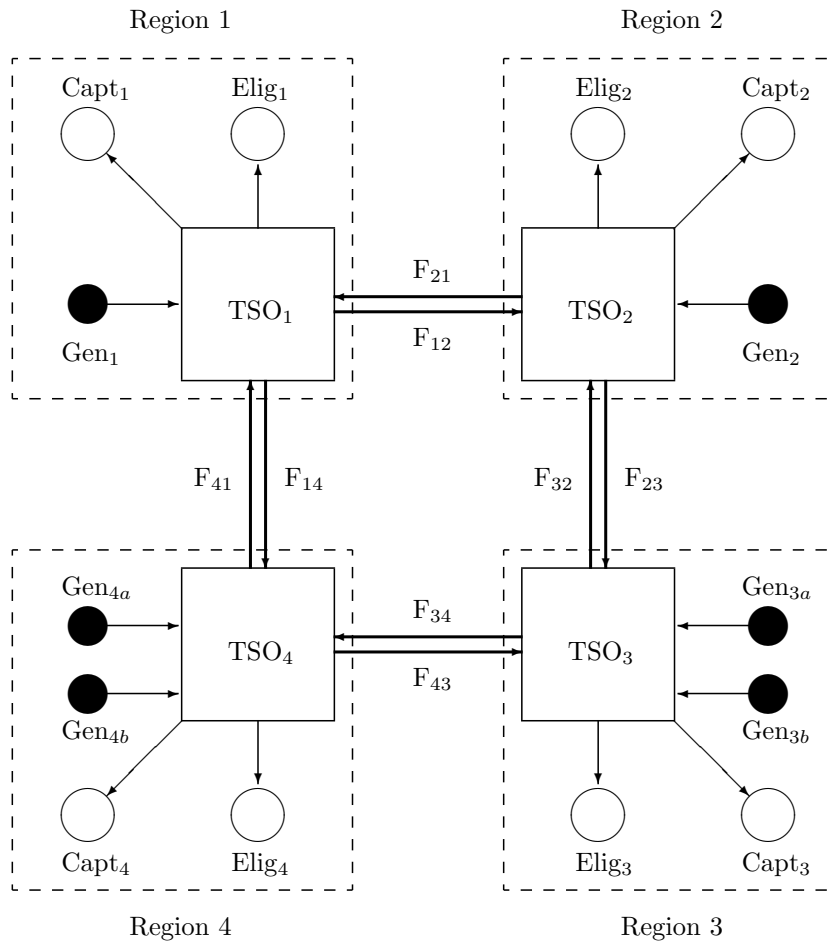

Figure 1: Stylised model

reference point and obtain the equation:

$$p^c = p_0^c \left(1 - \frac{1}{\varepsilon^c}\right) - \frac{p_0^c}{\varepsilon^c} q^c \quad (55)$$

In case there is no hypothesis about product differentiation (that is, in the case we consider all $\beta_{g,k}^c$ identical for a particular customer c), then the identification of parameters α^c and β^c is straightforward.

8.1.2 Generators Data

Generators are described by their generation cost function. We have seen in section 5 that this generation cost is given by:

$$CG_g(q_g) = K_g + \sum_{c \in C_g} vc_g^c q_g^c + \frac{1}{2} \sum_{c,l \in C_g} q_g^c \omega_g^{c,l} q_g^l \quad (56)$$

We will here make the simplifying assumption that, for a given generator g , the linear variable cost vc_g^c is the same for all its potential customers c , and that the quadratic part of its costs $\omega_g^{c,l}$ has the same value for each pair (c,l) of customers. Numerical data are provided in table 3, where fixed costs have been brought down to a hourly value.

8.1.3 Network Data

Network Operators (TSOs) also incur costs. We have stated in section 5 that their cost function is assumed to be linear, and given by the expression:

$$NC_r(q) = F^r + \sum_{(g,c) \in T_r} nc_{r,g}^c \times (f_{r,g}^c q_g^c) \quad (57)$$

where fixed costs are again reduced to their hourly equivalent value, and variable transmission costs are supposed to be small in comparison to generation costs. Moreover, variable transmission costs also depend on the power distribution factors $f_{r,g}^c$ indicating the fraction of a transaction from producer g to customer c which flows through region r . Table 4 gives the relevant cost information for TSOs.

Interconnection capacities are limited. We have chosen to implement a bi-directional representation of interconnections, which allows for capacities to be asymmetric. Table 6 gives the values in [MW] of the interconnection capacities. Note the asymmetry of the capacity of the line connecting network areas 1 and 4: the maximum flow from region 4 to region 1 is four times as important as in the opposite direction.

Finally, power distribution factors $f_{r,g}^c$ are implicitly defined by table 7, which describes for any transaction from region r to region r' , the amount of power flowing through the interconnections.

8.1.4 The Global Picture of the Model

While Eligible Customers are left to competition (possibly tuned by market power parameters), Captive Customers may be subject to regulation. The envisaged regulations are listed below, together with the corresponding abbreviation used in some result tables:

- Profit Maximisation (PROF)
- Price Cap mechanism (PCAP)
- Cost-Proportional Fully Distributed Costs (P-FDC)
- Quantity-based Fully Distributed Costs (Q-FDC)
- Revenue-based Fully Distributed Costs (R-FDC)
- Long Run Incremental Cost (LRIC)

The model has been implemented in GAMS, using CONOPT2 as non-linear solver. Some instances of the model require the DNLP (non-linear model with discontinuous derivatives) version of CONOPT2. This is the case when the costs $XTC_r(q)$ deemed caused by transit are computed using alternative A of ETSO's proposal, since this formulation involves a minimum function.

We successively consider the three versions of the model:

- the *Second-Stage Only*, where the parameter defining the repartition of network costs between generators and customers (λ_r) is fixed *a priori* to some arbitrary value,
- the *Nash equilibrium*, where each local regulator decides individually on the value of λ_r so as to maximise its local welfare, taking the choice of other regulators as given, and
- the *Cooperative equilibrium*, where the total welfare is maximised by the regulator, regardless of its repartition between agents.

For each of these three assumptions, we consider various combinations of captive market regulation, compensation mechanisms, competitive behaviours, as well as the sensitivity of the obtained solutions to some model parameters. Figure 2 summarises the different versions of the two-stage model.

THE FIRST-STAGE GAME

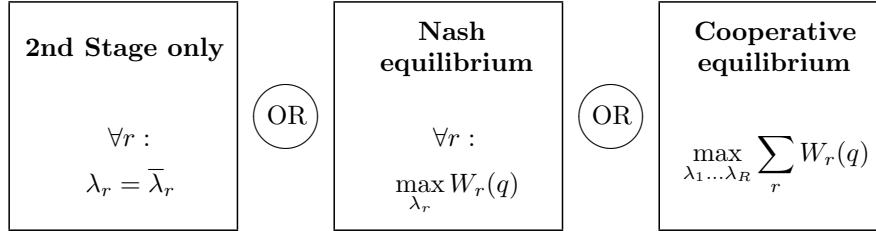

SECOND-STAGE EQUILIBRIUM

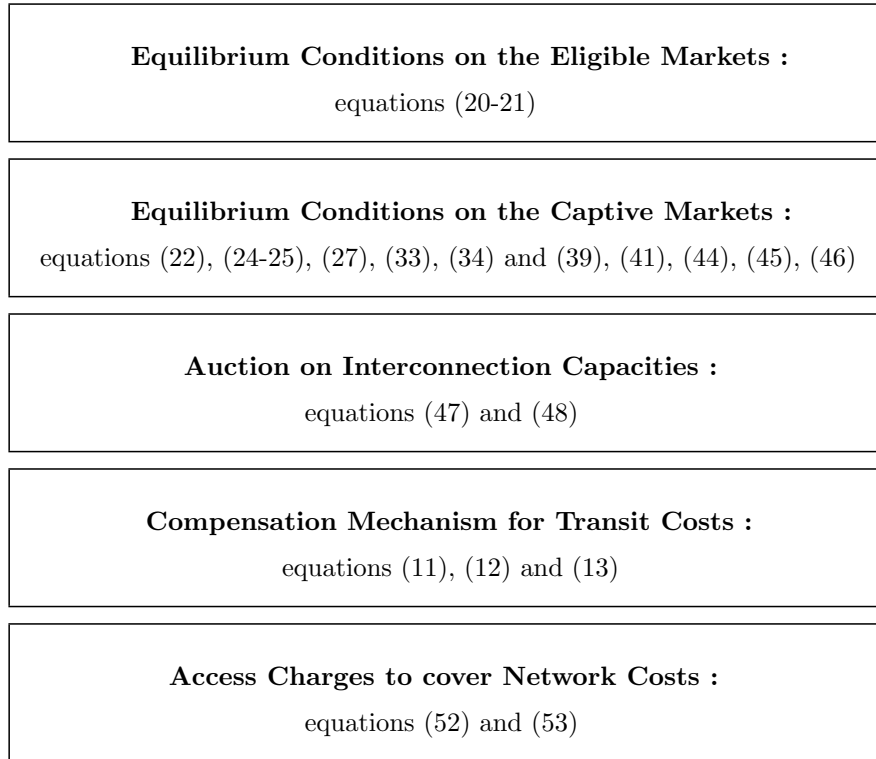

Figure 2: The global picture of the model

8.2 Second Stage Only

We first consider the version of the model where the allocation of network costs between generators and customers is fixed to arbitrary values. Several pricing rules are envisaged for the captive markets. This first version of the model assumes that competition in the eligible markets is represented by a Cournot equilibrium, where each agent is aware of its own impact on prices.

8.2.1 Profit Maximisation on Captive Markets

Tables 8 to 12, in appendix B, illustrate the numerical results for the second-stage equilibrium, when variables λ_r have been fixed *a priori* and captive markets are left to monopolistic pricing.

We take this configuration (referred to, in the following, as the *base case*) as a first reference. In this first example, the computation of transit costs is endogenous, and these costs are to be recovered exactly by means of the compensation fund. This corresponds to the lower-right cell of table 1 and is the most complex mechanism, where the whole inter-TSO payment is endogenous. We chose in a first step to use alternative B of formula (12) for the computation of transit costs.

The repartition of access charges between customers and generators has been fixed arbitrarily. We have assumed that network costs are entirely supported by customers ($\lambda_r = 0$) except in region 3 where we have adopted the opposite assumption. Note that the latter hypothesis is unrealistic in the sense that the EU regulation proposal [12, Art.4.2.] requires that the highest share of the network cost be imposed on customers. We nevertheless retain this extreme assumption in order to illustrate some surprising effects accruing from the lack of harmonisation of the allocation of network charges among EU countries.

The total welfare of the stylised system is equal to 3.817 million EUR for a single-hour representation of the problem. This should be viewed as a *worst case* scenario, because one does not try to optimise the regional welfare (second stage equilibrium only), and captive customers are left to monopolistic or oligopolistic profit maximisers.

Let us first look at the equilibrium costs and profits reported in table 8. We may easily verify that regulated TSOs have a zero-profit. Granting generators the right to use monopolistic or oligopolistic prices on their respective captive customers allows them to collect huge profits. Noticeably enough, in duopoly regions 3 and 4 (where, by data construction, generators Gen_{3a} and Gen_{4a} are presumed to be dominant operators with respect to their respective competitors Gen_{3b} and Gen_{4b}), the profits of the dominant generators are smaller than

these of their competitors, although the market share of the dominant generator remains slightly higher².

Customers utilities and surplus do not bring much insight at this early stage of results analysis, and are therefore not discussed at this stage. Note that in each region (except region 3), revenues from sales exceed local power purchase. This can be explained by the extreme hypothesis on the repartition of access charges between generators and customers. A generator located outside region 3 has no generation charge in its own region, and no customer charge if it supplies customers in region 3. It therefore gets a competitive advantage in region 3 on incumbent producers Gen_{3a} and Gen_{3b} which have to support the network charge in their region.

Table 9 reports the equilibrium volumes delivered to each customer. The comparison of these equilibrium values with the reference values in table 2 yields the following : captive customers supplied by a single monopolistic generator reach near 53% of their reference demand level, whereas captive customers supplied by two competitors get close to 70% of this reference level. On the other hand, eligible customers reach between 75 and 90% of their reference level. Equilibrium prices, given in the lower part of table 10, range between 63 and 83 EUR/MWh for captive customers, and lie around 34 EUR/MWh for eligible clients. This clearly illustrates the combined effect of the number of suppliers when no specific regulation is applied, and the higher price elasticity of the eligible customers.

Table 10 gives a quick overview of prices at the second-stage equilibrium. Marginal generation costs are in the range of 20 to 28 EUR/MWh. There is however a noticeable difference in marginal costs between generators installed in the same region (about 5 EUR/MWh). This difference arises from the second-stage equilibrium conditions (21) and (22)³. Access charges, as mentioned above, are fully supported by customers in all regions except in 3, where it is charged to generators only. The export tax is here endogenously computed in order to cover exactly the transit costs incurred by local TSOs. Its value of 1.27 EUR/MWh is quite realistic.

²Simplifying the problem to two generators a and b , with respective cost functions $K_i + vc \times q_i + \frac{1}{2}\omega_i q_i^2$, where $i = a, b$, and a single market (demand function $p = \alpha - \beta(q_a + q_b)$), we may show that at the Cournot equilibrium market shares are in the proportion $q_a/q_b = (\beta + \omega_b)/(\beta + \omega_a)$. In the numerical example, since β largely dominates both ω_a and ω_b in regions 3 and 4, market shares q_a and q_b are similar. The profit for the incumbent generator is equal to $\pi_a = -K_a + (\alpha - vc)^2(\beta + 0.5\omega_a)/(\omega_a + \beta \times (2 + (\beta + \omega_b)/(\beta + \omega_a)))^2 \approx -K_a + (\alpha - vc)^2/(9\beta)$, and the symmetric expression holds for generator b . Gross margins will hence also have the same order of magnitude. The difference in profits is therefore mainly caused by the larger fixed costs incurred by the incumbent generator.

³Considering the same example as in footnote 2, we know that at equilibrium q_a and q_b are similar, but marginal costs $vc + \omega_i q_i$ are not if ω_a and ω_b differ.

Table 11 displays the flows on the interconnections. Every generator located in areas 1, 2 or 4 tries to benefit from its competitive advantage in terms of access to region 3. For this reason, both lines connecting to region 3 are saturated. Dual values are obtained from equations (47) and can be interpreted as the prices coming out of the auction of the interconnection capacities. This leads to an auction value, for a supplementary MW of capacity from region 1 to region 3 (half of it flowing via region 2, the other half via region 4), of more than 7 EUR/MWh !

Finally, table 12 gives the details of the compensation mechanism under the assumption that the Compensation Fund covers exactly the transmission costs, through the collection of an endogenous export tax. Transmission costs being computed on the basis of equation (12-B), we need to measure the net flows I_r and O_r respectively in the import and export directions, as well as the local energy consumption and the local network cost. Applying the formula gives the share of the compensation fund which will be recovered by each of the TSOs. Note that although region 3 exclusively imports – and hence does not really suffer transit costs – they get the largest part in the Compensation Fund. This paradox arises from the formulation embedded in alternative B of the transit cost estimation: any cross-border transaction using the horizontal network in region 3 contributes to its transit costs, even if all of these transactions have their delivery point in this region. In economic terms, this amounts to reward region 3 which caused an externality. This is clearly an unintended consequence of the compensation mechanism. The total Compensation Fund amounts to 39 970 Euros for a single hour model (which nearly represents 350 million Euros on a yearly basis).

Sensitivity Analysis: the Compensation Mechanism. In section 5.4 we have envisaged several possible combinations of compensation mechanisms (*a priori* fixed fund or export tax, endogenous or exogenous transit costs, alternative computations of transit costs. . .). Table 13 gives an overview of the changes in the total welfare function, compensation fund and export tax, associated with these different mechanisms. Note that alternative A of the transit cost estimation does not perform very well: the problem is infeasible when we opt for a fixed tax (each region does either only import or only export: alternative A hence results in $XTC_r = 0$ in all regions, making equation 13 undefined), and it raises a very tiny compensation fund when transit costs are exactly recovered (in this case, regions 1 and 3 end up with no transit costs and hence no compensation because their respective flows are all in the same directions, i.e. exclusively export and exclusively import, respectively). These extreme situations are partly due to the single-period representation of our stylised model. ETSO however proposes to sum the values over each hour in the year, which

should somewhat smoothen the effects of this paradoxical mechanism. Even though this phenomenon may not be present in the real world, it signals that one of the rules proposed by ETSO is inoperative in extreme conditions and hence may have unintended effects in normal conditions.

The three different solutions obtained with *a priori* fixed compensation fund (first column) do not seem to depart significantly from each other in terms of global welfare. In contrast, the repartition of this welfare across the different regions changes. In particular, there is a transfer of welfare from region 4 to region 3 of about 12 thousand Euros between alternatives A and B. In short, the selection of inter-TSO payment mechanism matters.

Sensitivity Analysis: Market Power. We get interesting variants of the base case by tuning the market power parameters.

We can modify the assumed degree of competition between agents by changing the coefficient of conjectural variation $\xi_{g,k}^c (g \neq k)$. Setting the latter to a value of +1 leads to a collusive equilibrium between agents. In the latter case, all equilibrium volumes drop around 50% of the reference level. The end result is also disastrous in terms of welfare which decreases by almost 1 million Euros with respect to the *base case*. On the contrary, when set to a negative value, the equilibrium tends towards a price war. Probably because of the difficulty of covering the fixed charges of the network, the model does not find any feasible solution in case of extreme price war (that is, $\xi_{g,g}^c = +1$ and $\xi_{g,k}^c = -0.2$ for $g \neq k$, such that their sum equals -1 , see section 6). But solutions obtained with intermediate values (down to -0.173 instead of the theoretical limit of -0.2) show a significant increase in total welfare (+200 thousand Euros), while prices charged to eligible customer segments quickly drop towards marginal prices (27 to 30 EUR/MWh) although captive customers prices remain at their level (60 to 80 EUR/MWh).

These situations are interesting and deserve more investigation; they signal conditions where the allocation mechanisms hampers the development of competition, in this case by preventing a competitive equilibrium.

We can also play with the generator's awareness of its own impact on market price, by modifying the value of parameter $\xi_{g,g}^c$. When this parameter is set to +1, the agent is aware of the impact of its own decisions on market price. When set to 0, it is not aware at all and behaves like a price taker. Again this latter extreme case may lead to infeasible constraints because of the difficulty of covering the fixed costs of the network⁴. Keeping compensation mechanisms as

⁴In this particular case, a feasible solution can only be achieved with a relaxed version of the problem, where the compensation fund is exogenously set to zero, that is, when no compensation for alleged transit cost is enforced. The increase of welfare is however considerable,

in the *base case*, we get a feasible solution with values of $\xi_{g,g}^c$ down to 0.15, but cannot go below that value. The welfare reaches 4.533 million Euros, which is an increase of over 700 thousand Euros with respect to the *base case*, and prices on all customer segments drop significantly (around 29 EUR/MWh on eligible markets, and between 35 and 41 EUR/MWh for captive customers).

Sensitivity Analysis: Network Fixed Costs. Consider now the evolution of the dual values on interconnection capacities, for which we try to assess their evolution with respect to network fixed costs. To achieve this, we scale these fixed costs from 0.1 up to 3. Figure 3 illustrates the evolution of the dual values when network fixed costs increase. In order to plot only positive values, we reverted the connections R1-R4 and R4-R3. Interconnection R1-R2 never gets saturated, and hence its dual value is zero, and has therefore not been plotted. Note that two distinct behaviours appear as fixed costs of the network increase: on the one hand, the value of interconnections R2-R3 and R4-R3 increase continuously (up to some breakpoint) with network fixed costs. This could seem quite surprising. However, thinking back about our access charge assumptions, remember that transactions involving generators from regions 1, 2 or 4, to customers in region 3, do not bear any access charge. Therefore, when network costs increase, these “free” transactions become more and more attractive to generators, hence their willingness to pay for interconnection capacities increases as well. On the other hand, the dual value on line R1-R4 slowly decreases until the same breakpoint. This can be explained by the same assumption: transactions using this interconnection involve customers in region 1 or 2. These customers face increasing access charges when network costs grow. Hence the willingness to pay for interconnection capacity lessens. Once the scaling factor exceeds 2.6, line R1-R4 is not used at full capacity anymore, hence its dual value vanishes and this brings a change in the dual values of the remaining saturated interconnections. The latter starts again to increase after this breakpoint, up to the feasibility limit (reached with a scaling factor of 2.98).

8.2.2 Price Capped Profit Maximisation on Captive Markets

In this pricing rule, captive customers are protected by a regulated upper bound on their final price. We have arbitrarily chosen to set this cap to 50 EUR/MWh.

This results in a significantly increased total welfare (488 thousand Euros above the *base case*) : regions 1 and 2 increase their welfare by 30%, while in regions 3 and 4 it raises by 10% only. The reason therefore lies in their respective oligopolistic situation before the introduction of the price cap: monopolies are

since each customer (including captive ones) is now priced at marginal cost.

comparatively more detrimental than duopolies in terms of welfare. Introducing a price cap will therefore improve more on a former monopoly than on a duopoly.

This welfare improvement is not shared in the same manner by consumers and generators: for the former, the consumer surplus largely increases on captive markets. In contrast, monopolies dramatically reduce their profits (even though these remain slightly positive). Duopolies' position also change importantly. Incumbent generators restore a higher profit than in the *base case*, while their competitors see their profits collapse. Equilibrium volumes reach 83% of the reference level (instead of 53 to 70% in the *base case*) on the captive markets.

Equilibrium prices lie at their cap for captive markets and remain practically unchanged with respect to the *base case* on eligible markets. Although flows on interconnection capacities have not dramatically changed, the export tax reduces from 1.27 to 1.14 EUR/MWh. The collected compensation fund amounts to 35 800 Euros, and the share of this fund dedicated to regions 1 and 2 reduces slightly.

8.2.3 Cost-proportional Fully Distributed Cost on Captive Markets

Equilibrium relations have been stated in section 6.2.4 for captive markets. They impose that prices on captive market remain equal to some average cost. However, it is well known that average cost pricing mechanisms do not necessarily lead to a unique solution, neither do they guarantee the existence of a solution.

The total welfare now exceeds 4.44 million Euros, which is more than 625 thousand Euros above the *base case*. Each region gains around 4% anew on its local welfare with respect to the price cap regulation, and between 14% and 38% with respect to the profit maximisation. Again, this welfare increase is not equally distributed: captive customers see their price drop to levels ranging between 38 and 42 EUR/MWh, while eligible customers do not see significant changes. Generator profits, on the contrary, dramatically collapse – most of them now incur losses. The average cost pricing mechanism reduces the profit made on the captive market to zero (considering a given allocation of fixed costs to this captive market) and the competition on the eligible market does not guarantee sufficient revenues to cover the remaining fixed costs. The welfare increase hence mainly benefits to captive customers in each region.

One important change, however, with respect to the previous situations, is that the captive market of region 3 is exclusively supplied by generator Gen_{3a} . This can be explained through the non-convexity of inter-TSO compensation and pricing mechanism on captive markets, and a different starting point may lead to another solution⁵.

⁵Numerical experience show that this indeed is the case: starting from another initial point,

Equilibrium volumes increase once again on the captive markets, now ranging between 90 and 94% of their reference levels. Equilibrium flows only involve eligible customers and therefore remain almost unchanged. An increase in the local captive market consumption does however reduce the part $XTC_r(q)$ of network costs deemed to be due to transit and hence also reduces the total required compensation fund. This is the reason why the export tax drops once again, reaching 1.09 EUR/MWh, collecting a total amount of 34 200 Euros for the compensation fund. The shares θ_r of this compensation fund dedicated to each TSO do not change importantly with respect to the *base case*.

8.2.4 Quantity-based Fully Distributed Cost on Captive Markets

Here the common costs of each generator are allocated proportionally to its supplies. Again, neither the existence nor the uniqueness of a solution may be guaranteed.

The solution to this particular version of the problem is very similar to the previous instance, since the ratio of captive market deliveries to total generation is very close to the ratio of captive market direct generation costs to total direct generation costs. In fact, the values of variable $\psi_g^c(q_g)$ in formulations (30) and (32) do not differ significantly from the numerical data used in this example.

The total welfare, reaching 4.45 million Euros, is very slightly higher than in the case of Cost-Proportional FDC. The volumes at equilibrium also very slightly increase. The export tax remains at the same level and the compensation fund reaches 34 000 Euros.

8.2.5 Revenue-based Fully Distributed Cost on Captive Markets

From a computational point of view, this regulatory rule is probably the most difficult to solve because the inherent non-convexities of all involved functions. We do get a solution which is quite close to those obtained in the two previously discussed Fully Distributed Costs. In this case though, the captive customers in region 3 are being supplied by both their local generators.

Compared to the other FDC rules, the total welfare is somewhat reduced. It drops to 4.43 million Euros, and this loss is mainly incurred in region 3, where generator Gen_{3b} is back on the local captive market. Captive customer prices now rise up to 45 EUR/MWh in the latter region. The export tax is here 1.11 Eur/MWh and the total fund now amounts to 34 500 Euros for compensation.

one ends up with an equilibrium where both generators supply their internal market, but the global welfare is poorer.

Sensitivity Analysis: the Generation Fixed Costs. Generators incur fixed costs which have to be allocated according to some well-defined procedure in cost-allocation rules. An increase of these fixed costs may make it difficult to find solutions to our problem.

This happens, for instance, when raising every generator’s fixed costs by 50%. The problem becomes infeasible. This is not really a model issue but results from the need to allocate a large fixed cost. To overcome this issue, and nevertheless provide an insight into the problem, we introduce supplementary slacks in the equilibrium constraint (34), and solve the model with very high penalties on those tolerated violations. This is equivalent to searching for a feasible solution which departs in the least possible way from the covering of the fixed costs by the assumed allocation rule.

The end result is a solution where the welfare is seriously downgraded. It barely reaches 3.1 million Euros, that is, a decrease of the welfare by 1.33 million Euros, when the increase of generator fixed costs is “only” of 1.03 million Euros, the net loss hence comes close to 300 thousand Euros. Generators incur more losses with respect to the *base case* than customers increase their surplus. Equilibrium price do not change on the eligible markets, but come close to 60 EUR/MWh for captive customers.

8.2.6 Incremental Cost on Captive Markets

Incremental cost is the paradigm of economic efficiency. It does however not cover fixed costs incurred by operators, but maximises the total welfare. The implementation of Incremental Cost pricing leads to a total welfare of 4.53 million Euros, which represents an increase of 715 thousands with respect to the profit maximisation case. Only captive customers are priced with long-run incremental cost, however, which leads to a strange equilibrium where captive customer prices (ranging from 26 to 30 EUR/MWh) are lower than for eligible customers (which now lie in nearer to 35 EUR/MWh) that face imperfect competition.

All generators incur losses, since they cannot recover their fixed costs anymore on captive markets. Demand on the latter now reach 102 to 106% of their reference level. The export tax equals 1.05 EUR/MWh, for a total compensation fund of 32 500 Euros. The respective share θ_r of the Fund, recovered by each TSO, does not fundamentally change with respect to the *base case*.

8.3 Nash equilibrium between Regulators

Allowing the regulators to optimise their local welfare non-cooperatively leads to a Nash equilibrium (if any). Tables 14 and 15 summarise the main values

observed. As can be seen, equilibrium prices are barely affected by this move to a two-stage problem. However, observing the total welfare when moving to Nash equilibrium, we see that it improves by at least 20 thousand Euros (in P-FDC) to 35 thousand Euros (in PROF) with respect to the “second-stage only” welfare.

The Compensation Fund is also generally higher at the Nash equilibrium than at the corresponding “second-stage only” equilibrium. The intuitive reasoning therefore is that when each local regulator optimises separately its own welfare, it will try to get the largest possible share θ_r from the Compensation Fund. The solution at this equilibrium therefore shows flows I_r and O_r which are more important than in the “second-stage only problem”.

Figure 4 illustrates the evolution of dual values of saturated interconnection capacities in the case of Profit Maximisation, when network fixed costs are scaled from 0 to 3.6 times their reference value. Comparing this graph to figure 3, we observe a new behaviour: not only are the dual values smaller (in absolute value) than in the “second-stage only” model, but they also show a more chaotic behaviour. The changes in slope of the different curves coincides, as we will detail in subsection 8.4 dealing with cooperative behaviour, with structural changes in the corresponding evolution of access charges at one or the other end of the interconnection.

It is not obvious from table 15 that access to the network should be preferentially charged to generators or customers in the case of Nash equilibrium. One may however note that customers support a non-zero charge in almost every region and regulatory choice. Generators are left free of access charge in regions 1 and 3, but support the largest part of network costs in regions 2 and 4. While generators in region 4 are not very affected by this change, the profit of Gen_2 drops by 3 to 10 thousand Euros, depending on the regulation on the captive market.

8.4 Cooperative equilibrium between Regulators

Moving one step further towards welfare optimisation, we choose now to look at the total welfare, over all four regions, instead of independently optimising local welfare. We should therefore, in each scenario of regulation, obtain a total welfare which is greater than (or equal to) the value obtained in the corresponding Nash equilibrium. This may be verified from the results in table 14, where we see that total welfare is improved, when moving from Nash to Cooperative equilibrium, by at least 5 thousand Euros (in the case of LRIC) up to 10 thousands Euros (in the case of PCAP). With respect to the “second-stage only” equilibrium, the welfare increase reaches 26 to 40 thousands Euros.

Looking at equilibrium prices, however, we see that they are not dramatically modified by this move to a cooperative equilibrium. The main change (with respect to the Nash equilibrium) resides in the repartition of access charges between customers and generators. Looking at table 15, we can see that regions 3 and 4 are not affected (or very little) by the cooperation of regulators. On the contrary, regions 1 and 2 (the so-called smaller ones) are largely perturbed by this cooperation: in region 1, the access charge passes from 100% on customers to 100% on generators, and in region 2, it goes from roughly from a 70%/30% repartition in the Nash equilibrium to a 100% on generators in the cooperative equilibrium. The result is that generator Gen_1 loses between 5 and 10 thousand Euros (depending on the captive market rule) when switching from the Nash to the Cooperative equilibrium, while generator in region 2 increases its profit by roughly the same amount. Profits in regions 3 and 4 do not change significantly.

Looking at figures 5 to 7, we try to capture the sensitivity of dual values of saturated interconnection capacities, with respect to fixed network costs. Observe how changes in the dual values are linked to access charges in surrounding regions. The dual value on interconnection R4-R3, for instance, drops to zero (although still saturated) at the same point where a kink appears in the dual value on R1-R4 (at a level of 0.7 of the cost scaling factor). Looking at customer access charges in figure 6, we may see that customers in region 4 pay no access charge for low values of network costs, but begin to pay a positive charge when the cost scaling factor reaches 0.7, that is, exactly at the point where dual values on interconnections R1-R4 and R4-R3 change their behaviour. Similarly, the dual value on interconnection R2-R3 vanishes (at scaling factor 1.2) when customers in region 2 start to pay for access.

Important to mention is that the two interconnections R2-R3 and R3-R4 are still used at full capacity but their dual value is zero. We conjecture this to be a result of the multiplicity of solutions. Observe that as long as interconnections, or at least one of them, are saturated, then at least one dual value remains strictly non-zero. This is the case here for R4-R1, which remains positive up to a cost scaling factor of about 2.9, from which no line is being used at full capacity anymore. Note the apparent discontinuity of the dual value curves, together with the evolution of access charges, around the abscises in the interval $[2.7, 3.0]$. This seems to indicate that at least two distinct solutions are very close to each other in terms of welfare and that the non-linear solver “oscillates” between these solutions. Further, when summing up all individual values of access charges (to both customers and generators) plus the dual values on interconnection capacities, one gets a remarkably smooth quadratic curve, as shown in figure 8.

The above discussion shows that the allocation of network costs changes the perceived economic value of the interconnections. This phenomenon goes

to the point where one observes cases where the access charges are increased up to a level where the value of the interconnection becomes zero even though they remain saturated (but not tight). This indicates that the access charge and congestion management problems which have been considered separately by the Florence Forum and are commonly considered as distinct issues in the literature may be more interdependent than expected.

Finally, figure 9 illustrates the evolution of the total welfare across the different combinations of equilibria and regulations, setting the *base case* level at zero. The total welfare is hence very sensible to the retained regulation rule on captive markets, but its repartition among the agents (generators, captive and eligible customers) is fairly dependent on the equilibrium model (Second-Stage only, Nash or Cooperative).

9 Conclusion

This paper aims at the development of a conceptual and computational framework, destined to encompass the two important issues dealing with Cross-Border Trade, addressed by the “Florence Regulatory Forum”, namely congestion of interconnection capacities, and access to interconnected networks.

In short, our model manages the congestion of interconnection capacities through a coordinated auction, where each agent pays the opportunity cost for congested interconnection capacities. We have assumed a simplified *power distribution factors* system to determine the relative usage of interconnection by each transaction. The “auction” has been taken as the dual value of using congested interconnection capacities.

Pricing the access to interconnected networks does not only involve the coverage of local network costs in areas of injection and delivery. It also implies the contribution to transit costs induced on other regional networks through loop flows. ETSO has proposed several mechanisms intended to compensate for these transit costs: these have been surveyed in section 5.4, and we have implemented several combinations of these mechanisms in our computational framework.

The problem is cast in the form of a game between regional regulators, and is modelled by a two-stage equilibrium problem. In the first stage, regulators decide on the allocation of their regional network costs between generators and customers, taking the consequences of their decisions on the energy market into account. These consequences are assessed by modelling the energy market as a second-stage equilibrium, the latter being the result of imperfect competition on deregulated market, coupled with regulated pricing on the domestic captive markets. The “rules” that come out of the first-stage game largely influence the final equilibrium.

We consider three versions of this game. In a first version, regulators have no choice but to apply *a priori* allocation keys for their network costs; generators and customers then respond to these allocation rules and reach an equilibrium. This has been referred to as the *Second-Stage only* model. In a second alternative, regulators act separately in order to maximise their own regional welfare, assuming that other regulators will not react to their decisions. This leads to a *Nash equilibrium*. Finally, we considered the perspective of a single centralised regulator, which maximises the overall welfare, giving raise to a *Cooperative equilibrium*.

Several domestic regulations have been implemented and illustrated in this paper (including oligopoly pricing, price caps, various forms of fully distributed

costs and long-run incremental cost pricing). The design of the model allows for combinations of different regulations of captive markets in different regions. The analysis of all possible cases would in itself fill in several papers. We therefore restrained our attention to cases where all captive customers are subject to the same pricing rule, and assessed the impact of that regulation on the different equilibria.

Various forms of (imperfect) competition and market power also arise on the deregulated markets. The model copes with these different competitive assumptions through conjectural variation parameters. Their impact on equilibrium has been detailed on the *base case* of the numerical results (i.e. second-stage model only, subject to profit maximisation on captive markets and Cournot competition on eligible markets).

While equilibrium prices on the deregulated markets are rather insensitive to first-stage rules or regulation of domestic markets, they might however dramatically change depending on the assumptions on competitive behaviour (tackled through conjectural variation parameters). Prices on captive domestic markets, on the contrary, are mainly influenced by the regulatory assumption and (in some specific cases) the number of competing generators allowed to supply them.

Comparing the impact of the first-stage model alternatives to the domestic market regulations, we may see that the total welfare is mainly dependent on the regulation of the captive market, as illustrated in figure 9. However, the repartition of the welfare between the agents (mainly through the allocation of network costs between generators and customers) differs considerably, according to the network cost allocation rules selected in the first stage.

The various tests conducted indicate that the model performs as expected on those phenomena that we know well from economic theory. The assumptions of regulation on the non-eligible market as well as those of competition on the eligible market induce the right welfare effects. The possible distortion of competition that results from the allocation of the fixed costs of the network shows up as expected and welfare increases when one moves from a non-cooperative to a co-operative equilibrium. But the model also reveals questions that may deserve more analysis in a realistic case study. It reveals that some allocation methods foreseen by the compensation mechanism do not necessarily perform as expected. They may reward those deemed to cause transit cost. They may also become inapplicable in extreme conditions. This signals that they may not work well (that is, induce undesired effects) in non-extreme conditions. In some cases, it appears impossible to find an equilibrium when competition increases too much.

Even though both the compensation methods and allocations of network costs may not influence total welfare much, they drastically influence the allocation of that welfare. This is true whether across control areas or inside each area. Last but not least, the model reveals a close interaction between the access charge and the value of the interconnection. This indicates that these two problems which have been considered separately by the Florence Forum and are commonly seen as distinct issues in the literature may be more interdependent than expected.

Further improvements on this model involve data and computational issues. Going from the stylised model to a *real world* model not only involves data collection to accurately represent a larger number of regions, it also implies the development of a time dimension to account for the yearly procedures of the compensation mechanism. Both these aspects will contribute to a considerable increase in the model size, which potentially will result in some numerical problems.

References

- [1] Boucher J. and Y. Smeers (2001), *Towards a common European Electricity Market-Paths in the right direction ... still far from an effective design*, available from http://www.ksg.harvard.edu/hepg/standard_mkt_dsgn.htm
- [2] Boucher J. and Y. Smeers (2002), *Is Coordinated Auction the Recipe for Subsidiarity in Congestion Management?*, March 2002, mimeo, CORE, Louvain-la-Neuve.
- [3] Cadwalader M. D., Harvey S.M., Hogan W.W. and S. L. Pope (1999), *Coordinating Congestion Relief Across Multiple Regions*, October 1999, available from <http://ksghome.harvard.edu/~.whogan.cbg.ksg/>
- [4] Begg D. et al (1993), *Making Sense of Subsidiarity: How much Centralisation for Europe*, Center for Economic Policy Research, London
- [5] Chandley J. D., Harvey S.M. and W.W. Hogan (2000), *Electricity Market Reform in California*, available from <http://ksghome.harvard.edu/~.whogan.cbg.ksg/>
- [6] Chao H.P. and S. Peck (1996), *A market mechanism for electric power transmission*, Journal of Regulatory Economics, 10 pp 25-60.
- [7] European Commission (1986), *Council Resolution of September 16, 1986, concerning new Community Energy Policy Objectives for 1995 and Convergence of the Policies of the Member States*, Official Journal C 241, 25/09/1986.
- [8] European Commission (1996), *Directive 96/92/EC of the European Parliament and of the Council of December 19, concerning common rules for the internal market in electricity*, Official Journal L 027, 30/01/1997, p. 0020-0029, available from http://europa.eu.int/comm/energy/en/elec_single_market/index_en.html
- [9] European Commission (1999), *Second Report to the Council and the European Parliament on Harmonisation Requirements*, available from http://europa.eu.int/comm/energy/en/elec_single_market/index_en.html
- [10] European Commission (2001a), *The Internal market for Electricity The Florence process* available from http://europa.eu.int/comm/energy/en/elec_single_market/index_en.html
- [11] European Commission (2001b), *Communication of the Commission to Council and the European Parliament: Completing the internal energy*

- market*, COM(2001) 125 final, 13.03.2001, Commission of the European Communities, available from <http://europa.eu.int/comm/energy/en/internal-market/int-market.html>
- [12] European Commission (2001c), *Proposal for a Regulation of the European Parliament and of the Council on Conditions for Access to the Network for Cross-Border Exchanges in Electricity*, COM(2001) 125 final, 13.03.2001, Commission of the European Communities, provisional version available from <http://europa.eu.int/comm/energy/en/internal-market/int-market.html>
- [13] European Commission (2001d), *Proposal for a Directive of the European Parliament and of the Council on Conditions amending Directives 96/92/EC and 98/30/EC concerning common rules for the internal market in electricity and natural gas*, COM(2001) 125 final, 13.03.2001, Commission of the European Communities, provisional version available from <http://europa.eu.int/comm/energy/en/internal-market/int-market.html>
- [14] European Commission Press Release (2001e), *Towards a single energy market in 2005*, Commission Online, 13.03, 2001, Commission of the European Communities available from <http://europa.eu.int/comm/energy/en/internal-market/int-market.html>
- [15] ETSO (1999), *Evaluation of congestion management methods for cross-border transmission*, 11/1999 Florence Regulators Meeting, new June 2001 version available from <http://www.etso-net.org/>
- [16] ETSO (2000a), *Net Transfer Capacities (NTC) and Available Transfer Capacities (ATC) in the Internal Market of Electricity in Europe (IEM), Information for User*, March 2000, available from <http://www.etso-net.org/>
- [17] ETSO (2000b), *Cross-Border Tariffs for the Internal Market of Electricity in Europe*, March 2000, available from <http://www.etso-net.org>
- [18] ETSO (2001a), *Coordinated Use of Power Exchanges for Congestion Management*, Final Report, June 2001, available from <http://www.etso-net.org/>
- [19] ETSO (2001b), *Definition of Transfer Capacities in liberalized Electricity Markets*, April 2001, available from <http://www.etso-net.org/>
- [20] ETSO (2001c), *Coordinated Auctioning*, April 2001, available from <http://www.etso-net.org/>

- [21] ETSO (2001d), *Indicative values for Net Transfer Capacities (NTC) in Europe*, available from <http://www.ets-net.org/>
- [22] ETSO (2001e), *ETSO proposal for a temporary CBT mechanism*, available from <http://www.ets-net.org/>
- [23] ETSO (2002a), *ETSO Task Forces: Economic Rules for Cross-Border Trade*, February 2002, available from <http://www.ets-net.org/>
- [24] ETSO (2002b), *Objectives, Alternatives and Relevant Issues on the future Cross-Border Trade Mechanism*, February 2002, available from <http://www.ets-net.org/>
- [25] ETSO (2002c), *Coordinated Congestion Management: an ETSO vision*, February 2002, available from <http://www.ets-net.org/>
- [26] ETSO (2002d), *Reconciliation of Market Splitting with coordinated Auction Concepts*, February 2002, available from <http://www.ets-net.org/>
- [27] ETSO (2002e), *Coordinated Use of Power Exchanges for Congestion Management in Continental Europe: Market Design and Role of Power Exchanges*, February 2002, available from <http://www.ets-net.org/>
- [28] ETSO (2002f), *Design Options for Implementation of a Coordinated Transmission Auction*, February 2002, available from <http://www.ets-net.org/>
- [29] FERC (2001), *Electricity Market Design and Structure*, October 2001, available from <http://www.ksg.harvard.edu/hepg/>.
- [30] FERC (2002), *Working Paper on Standardized Transmission Service and Wholesale Electric Market Design*, March 2002, available from <http://www.ksg.harvard.edu/hepg/>.
- [31] Florence Regulatory Forum (2002), *The 2003 Cross-Border Tarification Mechanism*, Discussion Paper, February 2002, available from the Internal Market for Electricity website http://europa.eu.int/comm/energy/en/elec_single_market/florence/index_en.html
- [32] Hancher L. (1997), *Slow and not so Sure: Europe's Long March to Electricity Market Liberalization*, the Electricity Journal, 10 (9) pp 92-101.
- [33] Hancher L. (1998), *Delimitation of Energy law Jurisdiction: the EU and its Member States: From Organisational to Regulatory Conflicts*, Journal of Energy and Natural Resources Law, 16 (1) pp 42-67

- [34] Hancher L. (2000), *Cross-Border Transmission of Electricity in the European Energy Market: Regulatory Issues*, Journal of Network Industries, 1 pp 127-155
- [35] Hogan W.W. (2001), *California Electricity Market: Policy Meltdown* February 2001, available from <http://ksghome.harvard.edu/~.whogan.cbg.ksg/>
- [36] IAEW and Consentec (2001), *Analysis of Electricity Network Capacities and Identification of Congestion, Final Report*, December 2001, available from the Internal Market for Electricity website http://europa.eu.int/comm/energy/en/elec_single_market/index_en.html
- [37] Joskow P. (2001), *California's Electricity Crisis*, available from <http://econ-www.mit.edu/faculty/pjoskow/files/CALIFORNIA7-21-01.pdf>
- [38] Schweppe F.C., Caramanis M.C., Tabors R.E. and R.E. Bohn (1988), *Spot pricing of electricity*, Boston, Kluwer, Academic Publishers
- [39] Smeers Y. (2001a), *Market Incompleteness in Regional Electricity Transmission*, mimeo, CORE, Louvain-la-Neuve, available from <http://www.ksg.harvard.edu/hepg/flowgate.htm>
- [40] Smeers Y. (2001b), *What can the US learn from the European experience in the construction of real integrated electricity market*, September 2001, available from <http://www.ksg.harvard.edu/hepg/>.

A Numerical Data

Customer Segment	Reference Demand [GW]	Reference Price [EUR/MWh]	Price Elasticity [-]
Capt ₁	5.00	32.25	-0.30
Capt ₂	7.10	32.25	-0.30
Capt ₃	34.40	32.25	-0.30
Capt ₄	33.30	32.25	-0.30
Elig ₁	5.30	21.50	-0.50
Elig ₂	5.60	28.50	-0.50
Elig ₃	29.90	24.00	-0.50
Elig ₄	21.80	24.00	-0.50

Table 2: Customer Segment Characteristics

Generator Name	Hourly Fixed Costs [EUR]	Linear coefficient vc_g [EUR/MWh]	Quadratic coefficient ω_g [EUR/MWh/MWh]
Gen ₁	150 000	15.00	0.001150
Gen ₂	225 000	15.00	0.000600
Gen _{3a}	600 000	14.00	0.000375
Gen _{3b}	300 000	14.00	0.000750
Gen _{4a}	525 000	12.50	0.000265
Gen _{4b}	250 000	12.50	0.000525

Table 3: Producers Characteristics

Network Operator TSO	Hourly Fixed Costs [EUR]	Linear coefficient $nc_{r,g}^c$ [EUR/MWh]
Gen ₁	20 000	0.30
Gen ₂	30 000	0.40
Gen ₃	120 000	0.50
Gen ₄	150 000	0.50

Table 4: Transmission System Characteristics

<i>a priori</i> Computed Values for Transit Cost Compensation	
\overline{CF}	20 000 [EUR]
\bar{x}	1.0 [EUR/MWh]
\overline{XTC}_1	2 000 [EUR]
\overline{XTC}_2	3 000 [EUR]
\overline{XTC}_3	12 000 [EUR]
\overline{XTC}_4	15 000 [EUR]

Table 5: A priori values for Transit Compensation

Interconnection Capacities	Region 1	Region 2	Region 3	Region 4
Region 1	—	1 300	—	0 500
Region 2	1 300	—	2 750	—
Region 3	—	2 750	—	2 750
Region 4	2 000	—	2 750	—

Table 6: Interconnection Capacities Characteristics

Transactions	Interconnections				Local Networks			
	R1-R2	R2-R3	R3-R4	R4-R1	R1	R2	R3	R4
R1 \rightarrow R1	—	—	—	—	1.0	—	—	—
R1 \rightarrow R2	1.0	—	—	—	1.0	1.0	—	—
R1 \rightarrow R3	0.5	0.5	-0.5	-0.5	1.0	0.5	1.0	0.5
R1 \rightarrow R4	—	—	—	-1.0	1.0	—	—	1.0
R2 \rightarrow R1	-1.0	—	—	—	1.0	1.0	—	—
R2 \rightarrow R2	—	—	—	—	—	1.0	—	—
R2 \rightarrow R3	—	1.0	—	—	—	1.0	1.0	—
R2 \rightarrow R4	-0.7	0.3	0.3	-0.7	0.7	1.0	0.3	1.0
R3 \rightarrow R1	-0.5	-0.5	0.5	0.5	1.0	0.5	1.0	0.5
R3 \rightarrow R2	—	-1.0	—	—	—	1.0	1.0	—
R3 \rightarrow R3	—	—	—	—	—	—	1.0	—
R3 \rightarrow R4	—	—	1.0	—	—	—	1.0	1.0
R4 \rightarrow R1	—	—	—	1.0	1.0	—	—	1.0
R4 \rightarrow R2	0.7	-0.3	-0.3	0.7	0.7	1.0	0.3	1.0
R4 \rightarrow R3	—	—	-1.0	—	—	—	1.0	1.0
R4 \rightarrow R4	—	—	—	—	—	—	—	1.0

Table 7: Power Distribution Factors

B Numerical Results: Tables and Figures

	Region 1	Region 2	Region 3	Region 4
Network :	TSO_1	TSO_2	TSO_3	TSO_4
Fixed Cost	-20.00	-30.00	-120.00	-150.00
Variable Cost	-4.21	-6.91	-28.26	-27.16
Access Incomes	22.10	27.78	132.62	164.07
Compensation	2.11	9.13	15.64	13.09
Net Profit	0.00	0.00	0.00	0.00
Generators :	Gen_1	Gen_2	Gen_{3a}	Gen_{4a}
Fixed Cost	-150.00	-225.00	-600.00	-525.00
Generation Cost	-142.35	-210.42	-442.19	-404.39
Access Charge	-36.51	-53.56	-64.19	-105.80
Export Tax	-5.40	-8.55	-7.25	-10.20
Sales Revenues	382.53	575.41	1213.47	1244.11
Net Profit	48.26	77.87	99.85	198.72
			Gen_{3b}	Gen_{4b}
Fixed Cost	—	—	-300.00	-250.00
Generation Cost	—	—	-355.63	-343.32
Access Charge	—	—	-48.97	-71.49
Export Tax	—	—	-3.68	-4.88
Sales Revenues	—	—	941.60	925.33
Net Profit	—	—	233.32	255.65
Customers :	$Capt_1$ + $Elig_1$	$Capt_2$ + $Elig_2$	$Capt_3$ + $Elig_3$	$Capt_4$ + $Elig_3$
Power Purchase	-346.78	-484.75	-2363.08	-2087.84
Utility Function	489.88	722.02	3666.17	3308.08
Consumer Surplus	143.11	237.27	1303.09	1220.24
Welfare :				
Total: 3817.37	191.37	315.14	1636.25	1674.61

Table 8: Costs and Profits (in thousands EUR) at the Second-Stage equilibrium

	Volume	Gen ₁	Gen ₂	Gen _{3a}	Gen _{3b}	Gen _{4a}	Gen _{4b}
Capt ₁	2.63	2.63	—	—	—	—	—
Capt ₂	3.79	—	3.79	—	—	—	—
Capt ₃	23.78	—	—	12.55	11.23	—	—
Capt ₄	23.54	—	—	—	—	12.54	11.00
Elig ₁	4.12	0.53	0.57	0.91	0.40	1.16	0.55
Elig ₂	5.03	0.63	0.92	0.98	0.57	1.21	0.72
Elig ₃	22.85	2.17	3.72	5.68	3.10	5.64	2.55
Elig ₄	17.20	1.44	2.42	3.80	1.92	4.93	2.68

Table 9: Supplied Quantities [GW] at the Second-Stage equilibrium

	Region 1	Region 2	Region 3	Region 4
Local Marginal Cost				
Generator <i>a</i>	23.50	21.85	22.97	19.25
Generator <i>b</i>	—	—	27.11	24.20
Access Charges				
for customers	3.27	3.15	0.00	4.03
for generators	0.00	0.00	3.22	0.00
λ_r [-]	0.00	0.00	1.00	0.00
Export Tax (endog.)	1.27			
Supply Price				
Captive Cust.	83.26	82.38	65.43	63.75
Eligible Cust.	31.06	34.34	35.31	34.13

Table 10: Prices [EUR/MWh] at the Second-Stage equilibrium

	Lower Limit [MW]	Actual Flow [MW]	Upper Limit [MW]	Dual Value [EUR/MWh]
Connection				
R1 → R2	-1 300	146	1 300	—
R2 → R3	-2 750	2 750	2 750	6.21
R3 → R4	-2 750	-2 750	2 750	-5.74
R4 → R1	-500	-500	2 000	-2.15

Table 11: Interconnections: Flows, Bounds and Dual values

	Reg. 1	Reg. 2	Reg. 3	Reg. 4
Programmed Exchanges				
- Import [GW]	3.59	4.11	14.08	9.59
- Export [GW]	4.24	6.71	8.58	11.84
Measured Exchanges				
- Import [GW]	0.00	0.15	5.50	0.50
- Export [GW]	0.65	2.75	0.00	2.75
- Local Consumption [GW]	6.75	8.82	46.63	40.74
Compensation Mechanism				
Network Cost [kEUR]	24.21	36.91	148.26	177.16
Transit Cost [kEUR]	2.11	9.13	15.64	13.09
Share [-]	0.05	0.23	0.39	0.33
Export Contribution [kEUR]	5.40	8.55	10.93	15.08
Compensation Fund (endog.)	39.97			
Compensation [kEUR]	2.11	9.13	15.64	13.09

Table 12: Compensation Mechanism

	Fixed Fund \overline{CF}	Fixed Tax \bar{x}	Cost Recovery
Total Welfare [kEUR]			
Fixed \overline{XTC}_r	3812.46	3815.25	3815.29
Alternative $XTC_r^A(q)$	3811.95	INFES	3808.14
Alternative $XTC_r^B(q)$	3812.58	3815.44	3817.37
Compensation Fund [kEUR]			
Fixed \overline{XTC}_r	20.00	31.81	32.00
Alternative $XTC_r^A(q)$	20.00	INFES	2.51
Alternative $XTC_r^B(q)$	20.00	31.82	39.97
Export Tax [EUR/MWh]			
Fixed \overline{XTC}_r	0.62	1.00	1.01
Alternative $XTC_r^A(q)$	0.62	INFES	0.08
Alternative $XTC_r^B(q)$	0.62	1.00	1.27

Table 13: Welfare Sensitivity to the Compensation Fund mechanism

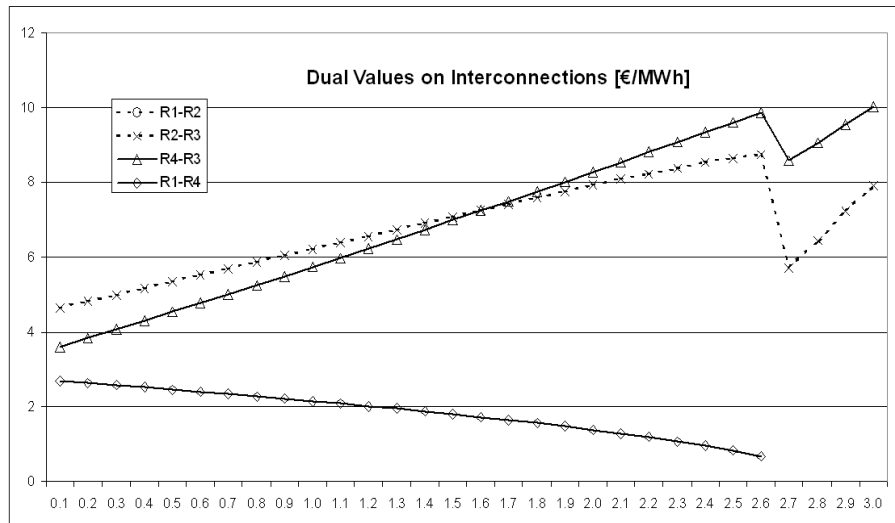

Figure 3: Dual Value on Interconnections as a function of Network Fixed Costs, in the Second-Stage equilibrium (using PROF regulation)

	2nd Stage Equilibrium	Nash Equilibrium	Cooperative Equilibrium
Total Welfare [million EUR]			
PROF	3.817	3.852	3.858
PCAP	4.305	4.328	4.338
R-FDC	4.429	4.458	4.464
P-FDC	4.443	4.464	4.469
Q-FDC	4.452	4.475	4.481
LRIC	4.533	4.558	4.563
Capt. Mkt Price [EUR/MWh]			
PROF	63 ... 83	64 ... 83	64 ... 83
PCAP	50	50	50
R-FDC	38 ... 45	38 ... 44	38 ... 44
P-FDC	38 ... 42	38 ... 44	38 ... 44
Q-FDC	38 ... 42	37 ... 42	37 ... 42
LRIC	26 ... 30	26 ... 29	26 ... 29
Elig. Mkt Price [EUR/MWh]			
PROF	31 ... 35	32 ... 35	31 ... 35
PCAP	31 ... 35	32 ... 36	31 ... 35
R-FDC	32 ... 36	33 ... 36	32 ... 36
P-FDC	32 ... 35	33 ... 36	32 ... 36
Q-FDC	32 ... 35	33 ... 36	32 ... 36
LRIC	32 ... 36	33 ... 36	32 ... 36
Comp. Fund [EUR]			
PROF	39 970	43 530	39 290
PCAP	35 790	33 130	36 100
R-FDC	34 480	36 410	34 580
P-FDC	34 210	36 470	34 560
Q-FDC	34 050	36 300	34 430
LRIC	32 480	34 370	32 910

Table 14: Comparison of equilibria and regulations: Welfare, Equilibrium Prices and Compensation Fund

	2nd Stage Equilibrium	Nash Equilibrium	Cooperative Equilibrium
Region 1 (G / L) [EUR/MWh]			
PROF	0.00 / 3.27	0.00 / 3.03	3.09 / 0.00
PCAP	0.00 / 2.82	0.00 / 2.71	2.65 / 0.00
R-FDC	0.00 / 2.72	0.00 / 2.61	2.57 / 0.00
P-FDC	0.00 / 2.71	0.00 / 2.60	2.56 / 0.00
Q-FDC	0.00 / 2.70	0.00 / 2.59	2.55 / 0.00
LRIC	0.00 / 2.58	0.00 / 2.49	2.44 / 0.00
Region 2 (G / L) [EUR/MWh]			
PROF	0.00 / 3.15	2.42 / 0.00	2.41 / 0.00
PCAP	0.00 / 2.76	1.53 / 0.81	2.18 / 0.00
R-FDC	0.00 / 2.65	1.49 / 0.77	2.12 / 0.00
P-FDC	0.00 / 2.65	1.60 / 0.63	2.11 / 0.00
Q-FDC	0.00 / 2.64	1.61 / 0.61	2.11 / 0.00
LRIC	0.00 / 2.53	1.56 / 0.59	2.04 / 0.00
Region 3 (G / L) [EUR/MWh]			
PROF	3.22 / 0.00	0.00 / 2.83	0.00 / 2.83
PCAP	2.96 / 0.00	0.00 / 2.69	0.00 / 2.64
R-FDC	2.89 / 0.00	0.00 / 2.58	0.00 / 2.58
P-FDC	2.83 / 0.00	0.00 / 2.57	0.00 / 2.57
Q-FDC	2.82 / 0.00	0.00 / 2.56	0.00 / 2.56
LRIC	2.70 / 0.00	0.00 / 2.44	0.00 / 2.44
Region 4 (G / L) [EUR/MWh]			
PROF	0.00 / 4.03	2.71 / 1.16	2.57 / 1.31
PCAP	0.00 / 3.71	3.64 / 0.00	2.75 / 0.83
R-FDC	0.00 / 3.50	2.50 / 0.88	2.41 / 0.97
P-FDC	0.00 / 3.51	2.45 / 0.94	2.36 / 1.04
Q-FDC	0.00 / 3.49	2.47 / 0.91	2.37 / 1.01
LRIC	0.00 / 3.30	3.16 / 0.00	3.15 / 0.00

Table 15: Comparison of equilibria and regulations: Access Charges for Generators (G) and Customers (L)

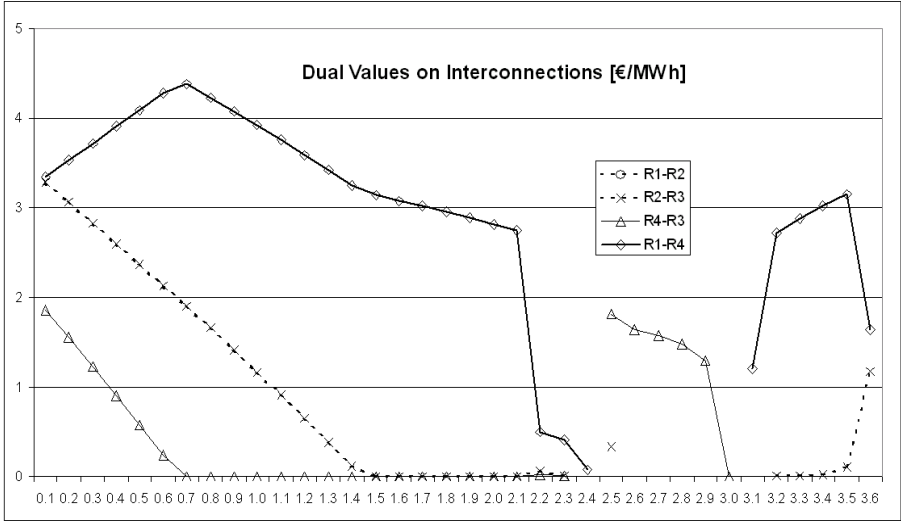

Figure 4: Dual Value on Interconnections as a function of Network Fixed Costs, in the 2-Stage Nash equilibrium (using PROF regulation)

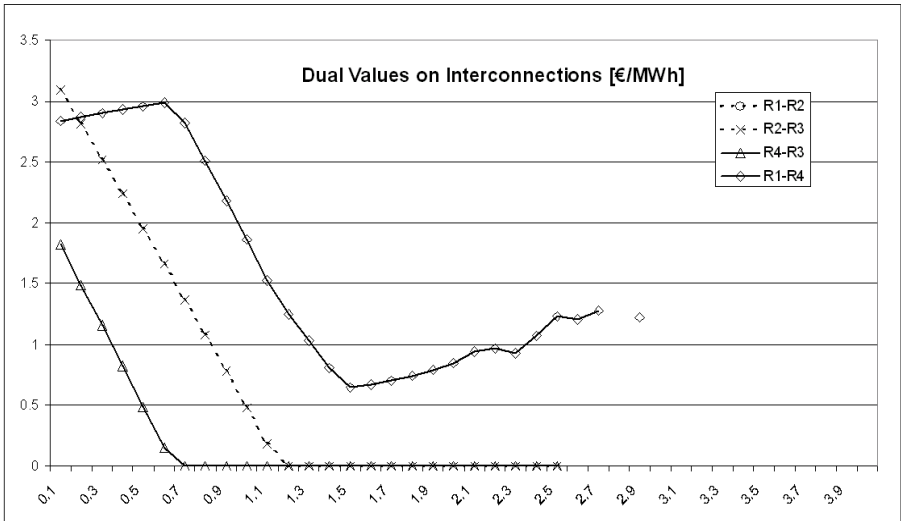

Figure 5: Dual Value on Interconnections as a function of Network Fixed Costs, in the 2-Stage Cooperative equilibrium (using PROF regulation)

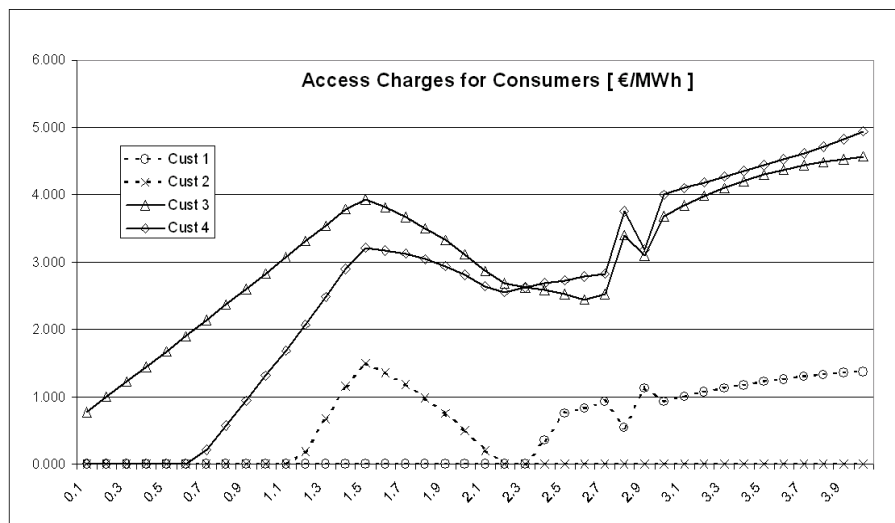

Figure 6: Access charge for Customers as a function of Network Fixed Costs, in the 2-Stage Cooperative equilibrium (using PROF regulation)

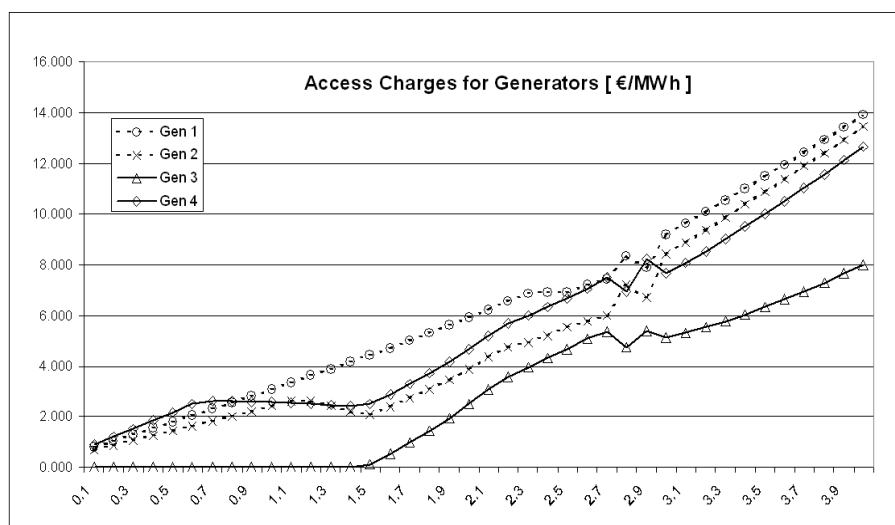

Figure 7: Access charge for Generators as a function of Network Fixed Costs, in the 2-Stage Cooperative equilibrium (using PROF regulation)

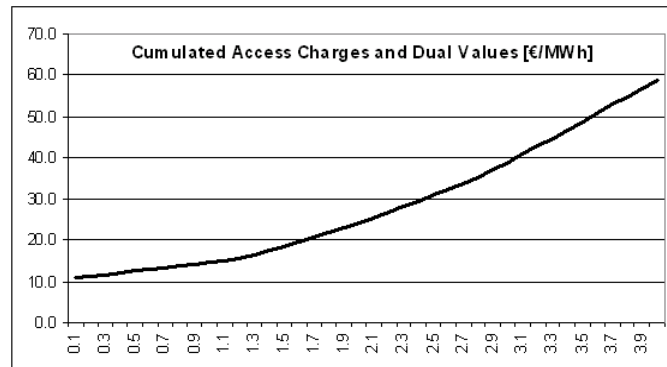

Figure 8: Cumulated access charges for customers, generators, and dual values of interconnection capacities, as a function of Network Fixed Costs (using PROF regulation)

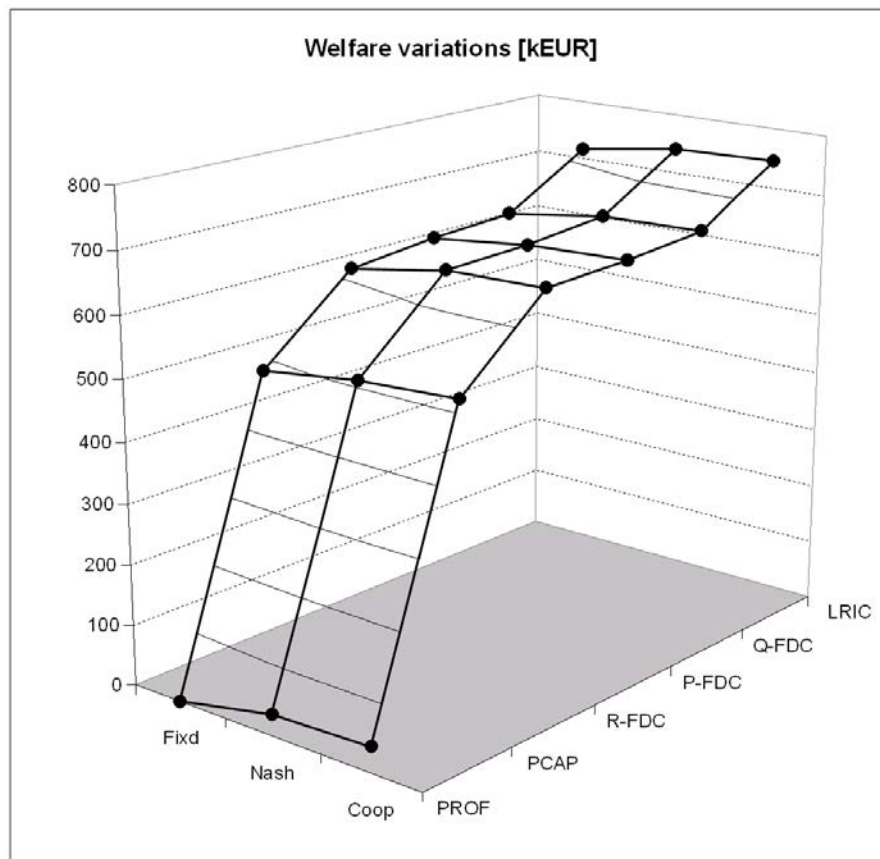

Figure 9: Welfare Increases with respect to the Base Case [kEUR]