

# ***Cambridge Working Papers in Economics CWPE 0407***



UNIVERSITY OF  
CAMBRIDGE  
Department of  
Applied Economics

## **Recent Blackouts in US and Continental Europe: Is Liberalisation to Blame?**

***Janusz W. Bialek***

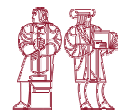

The  
Cambridge-MIT  
Institute

*Massachusetts Institute of Technology  
Center for Energy and  
Environmental Policy Research*

## ***CMI Working Paper 34***

# ***DAE Working Paper Series***



UNIVERSITY OF  
CAMBRIDGE  
Department of  
Applied Economics

**not to be quoted without  
permission**



The  
Cambridge-MIT  
Institute

*Massachusetts Institute of Technology  
Center for Energy and  
Environmental Policy Research*

# ***CMI Working Paper Series***

# Recent blackouts in US and continental Europe: is liberalisation to blame?

Janusz W. Bialek  
University of Edinburgh  
Institute for Energy Systems  
[Janusz.Bialek@ed.ac.uk](mailto:Janusz.Bialek@ed.ac.uk)

16 January 2004.

## Abstract

The paper starts with a detailed technical overview of recent blackouts in the US, Sweden/Denmark and Italy in order to analyse common threads and lessons to be learnt. The blackouts have exposed a number of challenges facing utilities worldwide. Increased liberalisation of electricity supply industry has resulted in a significant increase in inter-area (or cross-border) trades which often are not properly accounted for when assessing system security. The traditional decentralised way of operating systems by TSOs, with each TSO looking after its own control area and little information exchange, resulted in inadequate and slow response to contingencies. A new mode of coordinated operation for real-time security assessment and control is needed in order to maintain system security. This new mode of operation requires overcoming a number of organisational, psychological, legal and technical challenges but the alternative is either to risk another blackout or run the interconnected system very conservatively, maintaining large security margin at a high cost to everyone. The paper also includes technical appendices explaining engineering power system concepts to non-engineering audience.

## 1 Introduction

It looked like a fast spreading epidemic: 6 blackouts within 6 weeks in the late summer of 2003 affecting about 112 million people in US, UK, Denmark, Sweden and Italy. Hardly ever power engineering was so frequently on the front pages of newspapers (if for all the wrong reasons). People started to ask questions: is it a coincidence, is liberalisation to blame, who is the next? This paper starts with describing blackouts themselves in order to discover common threads and some early lessons to be learnt.

There are several common features regarding all the recent blackouts. They were all transmission-based, i.e. there were no problems at the time with the level of generation. The systems were not stressed before the blackouts occurred – in Italy the blackout even happened at night. There is however one main difference between the blackouts in the US and continental Europe and those in the UK<sup>1</sup>. In the former, the blackouts started at the interconnections between neighbouring networks and spread across boundaries. In the UK, the two blackouts were very similar to each other but

---

<sup>1</sup> The two local blackouts in the UK (London and Birmingham) happened on 28 August and 5 September 2003.

were both within a control area managed by National Grid. This paper concentrates on the blackouts in US and continental Europe leaving the UK events for another time.

## 2 US blackout on 14 August 2003

The blackout was triggered by some initial innocuous-looking outages in northern Ohio, which spread to the whole region. 62 GW were lost, about 50 million people were affected, full restoration took several days. This section contains a high-level description of events and is composed almost exclusively of extracts from [1].

Figure 1 shows the geographical area and the control areas in the area of the blackout<sup>2</sup>. It is worth noting that the events involved directly 6 control areas. The disturbances started in northern Ohio controlled by FirstEnergy (FE). Figure 2.1 shows the overview of power flows in the area before the cascade started. Northern Ohio (shaded in Figure 2.1) was supplied directly from the south and indirectly, via PJM, from the west along Lake Erie. Michigan (to the left of Lake Erie) was also supplied from the south while Ontario (to the north of Lake Erie) was supplied from two sides; from the east via Michigan and from the west via PJM and New York.

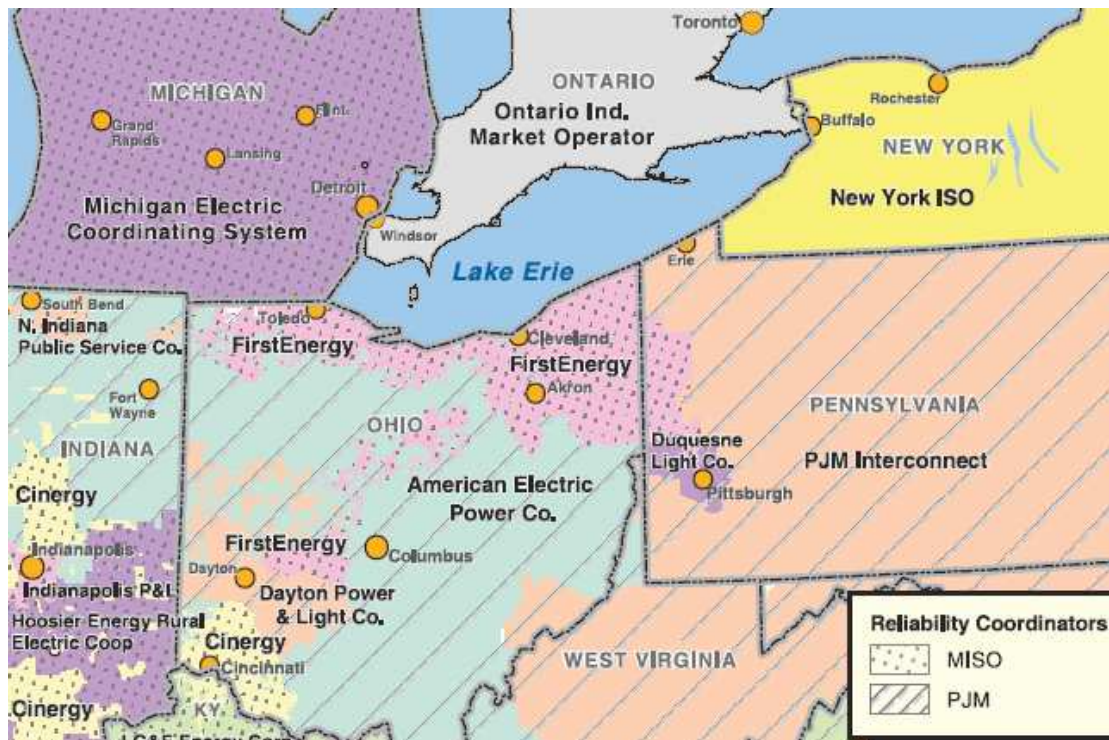

Figure 1 Reliability Coordinators and Control Areas in the area affected by the blackout [1].

### 2.1 Description of events

#### Phase 1: A Normal afternoon degrades

Northern Ohio was experiencing an ordinary August afternoon, with loads moderately high to serve air conditioning demand. FE managers referred to it as peak load

<sup>2</sup> Control Area is a geographic area within which a single entity, Independent System Operator (ISO) or Regional Transmission Organisation (RTO), balances generation and demand in real time to maintain reliable operation.

conditions on a less than peak load day. The voltages were low but consistent with historical voltages. FE was importing approximately 2,500 MW (21% of system demand) into its service territory, causing its system to consume high levels of reactive power<sup>3</sup>. With two of Cleveland's active and reactive power production anchors already shut down, the loss of another unit, Eastlake 5, at 13:31 further depleted critical voltage support for the Cleveland-Akron area. The cause of the trip was that as the Eastlake 5 operator sought to increase the unit's reactive power output, the unit's protection system detected a failure and tripped the unit off-line. The loss of the Eastlake 5 unit did not put the grid into an unreliable state—i.e., it was still able to withstand safely another contingency. However, the loss of the unit required FE to import additional power to make up for the loss of the unit's output (540 MW), made voltage management in northern Ohio more challenging, and gave FE operators less flexibility in operating their system.

At 14:02 EDT, Dayton Power & Light's (DPL) Stuart-Atlanta 345-kV line tripped off-line due to a tree flashover<sup>4</sup>. This line had no direct electrical effect on FE's system—but it did affect Midwest Independent System Operator (MISO) performance as reliability coordinator, even though PJM is the reliability coordinator for the DPL line. One of MISO's primary system condition evaluation tools, its state estimator, was unable to assess system conditions for most of the period between 12:37 EDT and 15:34 EDT, due to a combination of human error and the effect of the loss of DPL's Stuart-Atlanta line on other MISO lines as reflected in the state estimator's calculations. Without an effective state estimator, MISO was unable to perform contingency analyses of generation and line losses within its reliability zone. Therefore, through 15:34 EDT MISO could not determine that with Eastlake 5 down, other transmission lines would overload if FE lost a major transmission line, and could not issue appropriate warnings and operational instructions.

### **Phase 2: FE's Computer Failures. 14:14 EDT to 15:59 EDT**

Starting around 14:14 EDT, FE's control room operators lost the alarm function that provided audible and visual indications when a significant piece of equipment changed from an acceptable to problematic condition. Shortly thereafter, the Energy Management System (EMS) system lost a number of its remote control consoles. Next it lost the primary server computer that was hosting the alarm function, and then the backup server such that all functions that were being supported on these servers were stopped at 14:54 EDT. However, for over an hour no one in FE's control room grasped that their computer systems were not operating properly, even though FE's Information Technology support staff knew of the problems and were working to solve them, and the absence of alarms and other symptoms offered many clues to the operators of the EMS system's impaired state. Thus, without a functioning EMS or the knowledge that it had failed, FE's system operators remained unaware that their electrical system condition was beginning to degrade. Unknowingly, they used the outdated system condition information they did have to discount information from others about growing system problems.

---

<sup>3</sup> see Appendix A for the primer on reactive power.

<sup>4</sup> see Appendix B for the reasons why lines sag due to increased loading and may contact a tree.

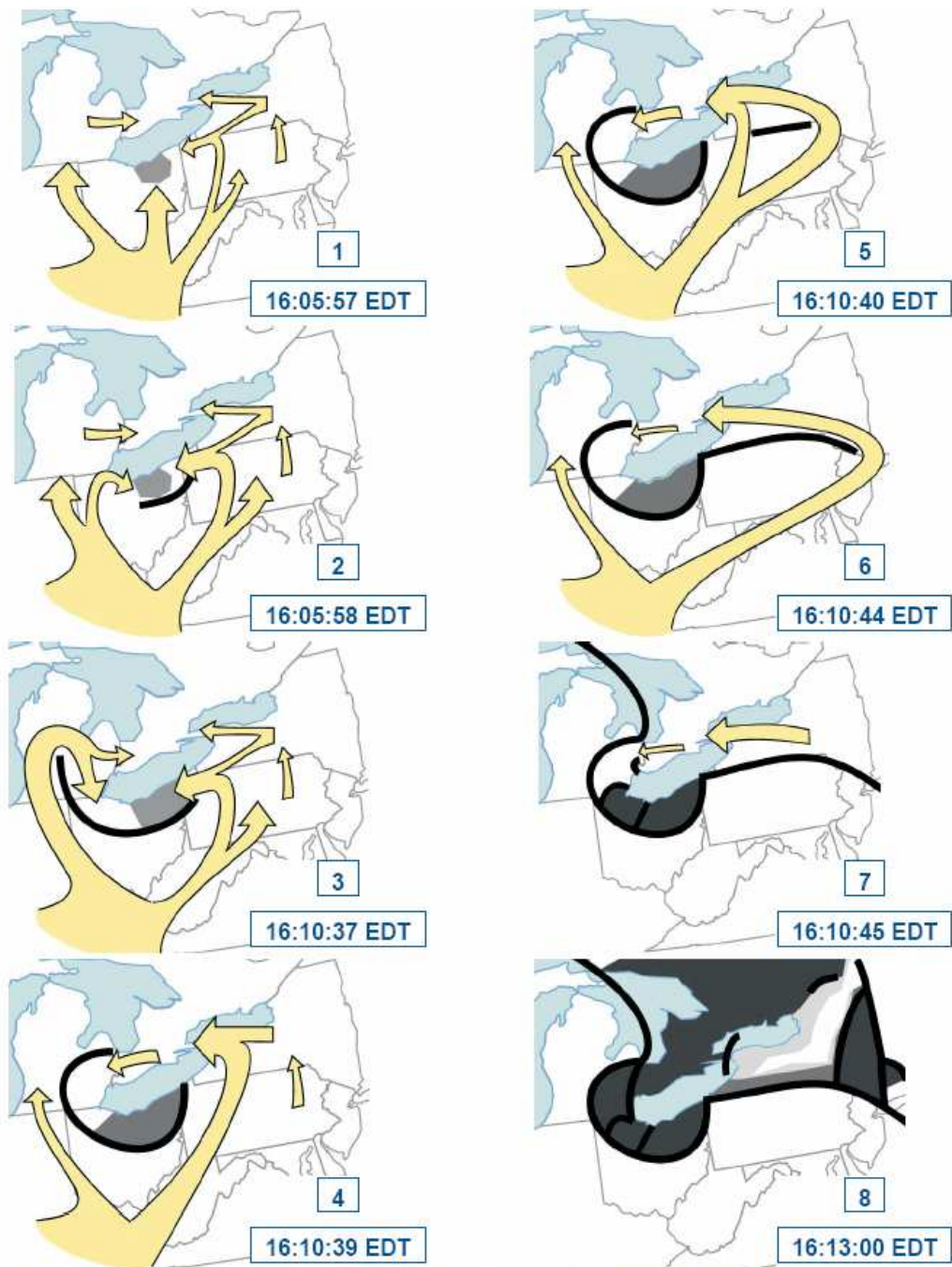

Figure 2 Overview of power flows during the blackout [1].

### Phase 3: Three FE 345-kV Transmission Line Failures. 15:05 EDT to 15:57 EDT

From 15:05:41 EDT to 15:41:35 EDT, three 345-kV lines tripped in Cleveland area at 43.5%, 87.5% and 93.2%, respectively, of their normal and emergency line rating. Each trip was the result of a contact between a line and a tree that had grown so tall that, over a period of years, it encroached into the required clearance height for the line. As each of the transmission lines failed, power flows shifted to other



transmission paths increasing their loading and resulting in further trips. Additionally, voltages on the rest of FE's system degraded further (Figure 3)<sup>5</sup>.

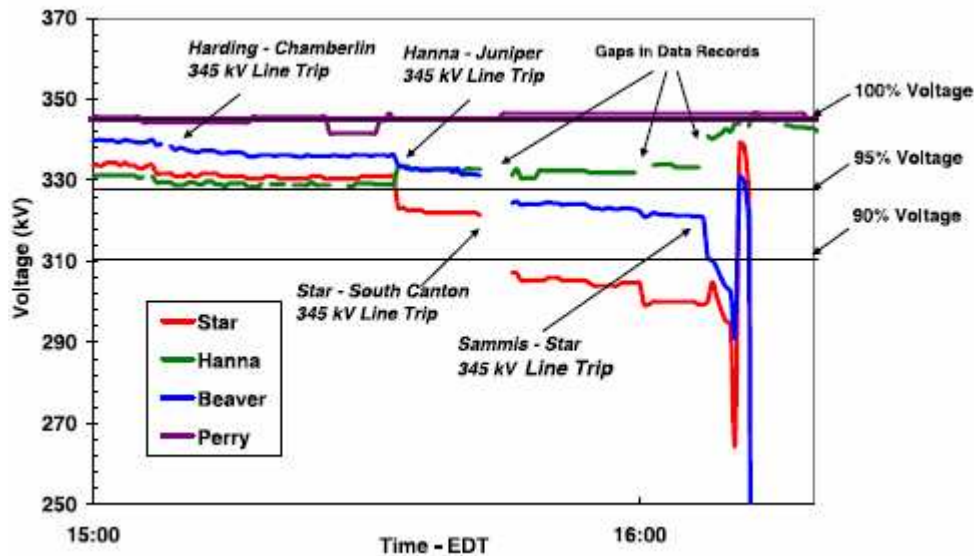

Figure 3 Voltages on FirstEnergy's 345-kV Lines: Impacts of Line Trips [1].

#### **Phase 4: 138-kV Transmission System Collapse in Northern Ohio. 15:39 to 16:08 EDT**

As each of FE's 345-kV lines in the Cleveland area tripped out, it increased loading and decreased voltage on the underlying 138-kV system serving Cleveland and Akron, pushing those lines into overload. Starting at 15:39 EDT, the first of an eventual sixteen 138-kV lines began to fail. As these lines failed, the resulting voltage drops caused a number of large industrial customers with voltage-sensitive equipment to go off-line automatically to protect their operations. As the 138-kV lines tripped out, they blacked out customers in Akron and the areas west and south of the city, ultimately dropping about 600 MW of load.

#### **Phase 5: 345-kV Transmission System Cascade in Northern Ohio and South-Central Michigan**

The collapse of FE's transmission system induced unplanned power surges across the region. Shortly before the collapse, large electricity flows were moving across FE's system from generators in the south (Tennessee, Kentucky, Missouri) to load centers in northern Ohio, eastern Michigan, and Ontario - Figure 2.1. This pathway in northeastern Ohio became unavailable with the collapse of FE's transmission system. The electricity then took alternative paths to the load centres located along the shore of Lake Erie - Figure 2.2. Power surged in from western Ohio and Indiana on one side and from Pennsylvania through New York and Ontario around the northern side of Lake Erie. Transmission lines in these areas, however, were already heavily loaded with normal flows, and some of them began to trip.

#### **Phase 6: The Full Cascade: 16:10:36 EDT to 16:10:45 EDT**

The northeast then separated from the rest of the Eastern Interconnection due to these additional power surges. The power surges resulting from the FE system failures

<sup>5</sup> See Appendix A for the reasons why increased line loading degrades voltages.

caused lines in neighbouring areas to see overloads that caused impedance relays to operate<sup>6</sup>. The result was a wave of line trips through western Ohio that separated AEP from FE - - Figure 2.3. Then the line trips progressed northward into Michigan separating western and eastern Michigan - - Figure 2.4. With paths cut from the west, a massive power surge flowed from PJM into New York and Ontario in a counter-clockwise flow around Lake Erie to serve the load still connected in eastern Michigan and northern Ohio - - Figure 2.4. Power flow from Ontario into Detroit suddenly changed direction and a period of sustained oscillations ensued indicating system instability – see Figure 4. The impedance relays on the lines between PJM and New York saw the massive power surge as faults and tripped those lines. Lines in western Ontario also became overloaded and tripped - - Figure 2.5 and Figure 2.6. The entire northeastern United States and the province of Ontario then became a large electrical island separated from the rest of the Eastern Interconnection -- Figure 2.7. This large island, which had been importing power prior to the cascade, quickly became unstable as there was not sufficient generation in operation within it to meet electricity demand. Systems to the south and west of the split, such as PJM, AEP and others further away remained intact and were mostly unaffected by the outage. Once the northeast split from the rest of the Eastern Interconnection, the cascade was isolated.

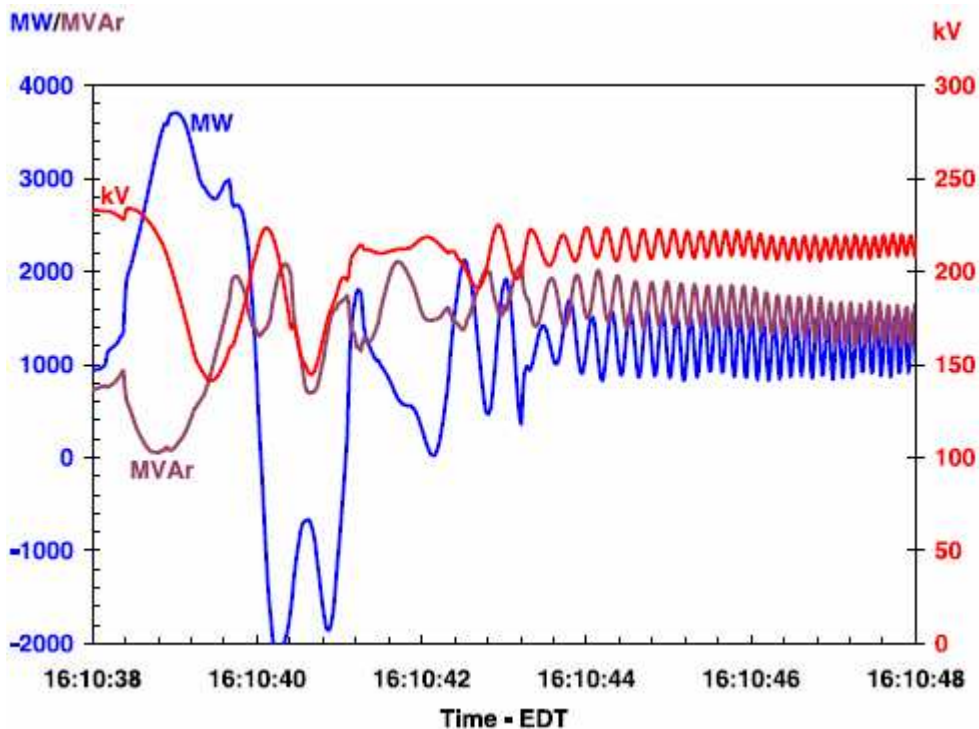

Figure 4 Active and reactive power and voltage from Ontario into Detroit [1].

### Phase 7:

#### Several Electrical Islands Formed in Northeast U.S. and Canada: 16:10:46 EDT to 16.12 EDT

In the final phase, the large electrical island in the northeast was deficient in generation and unstable with large power surges and swings in frequency and voltage.

<sup>6</sup> See Appendix B to understand how impedance relays work.



As a result, many lines and generators across the disturbance area tripped, breaking the area into several electrical islands - Figure 2.8. Generation and load within these smaller islands was often unbalanced, leading to further tripping of lines and generating units until equilibrium was established in each island. Although much of the disturbance area was fully blacked out in this process, some islands were able to reach equilibrium without total loss of service. For example, most of New England was stabilised and generation and load restored to balance. Approximately half of the generation and load remained on in western New York, which has an abundance of generation, mostly hydro which was less affected by the disturbances. By comparison, other areas with large load centres and insufficient generation nearby to meet that load collapsed into a blackout condition.

Figure 5 shows frequency data for the area affected by the blackout. Frequency in an interconnected system is everywhere the same so separation of frequency plots for different areas indicates creation of an electrical island. The data reveal at least five separate electrical islands in the Northeast as the cascade progressed. The two paths of red diamonds on the frequency scale reflect the Albany area island (upper path) versus the New York city island, which declined and blacked out much earlier.

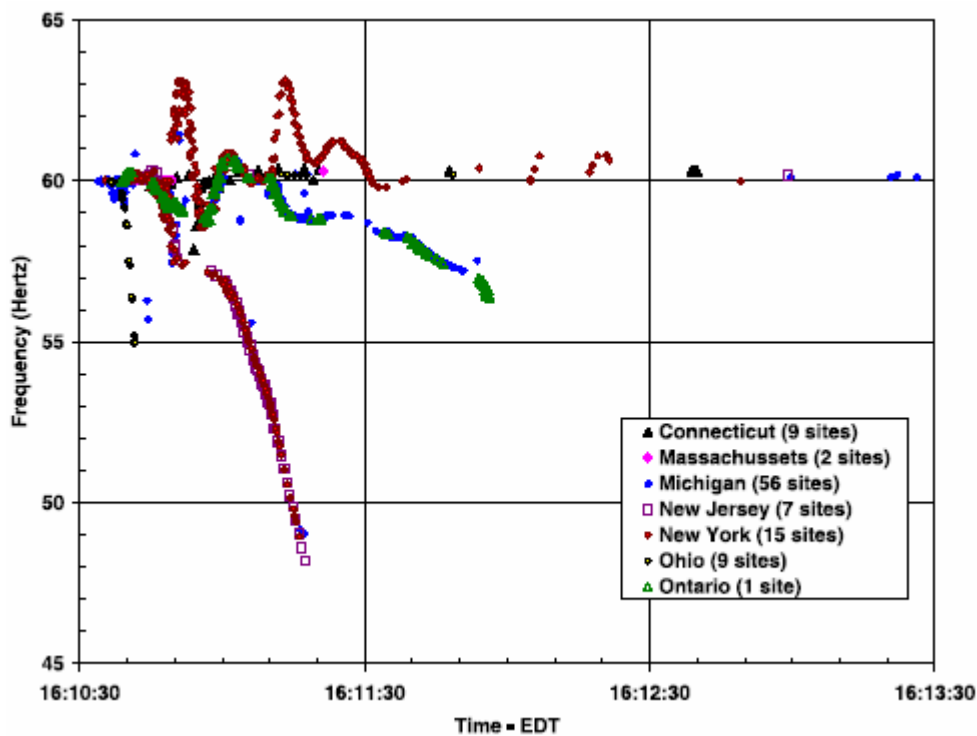

Figure 5 Electric Islands Reflected in Frequency Plot [1].

## 2.2 Who's to blame?

Interim Report [1] puts blame almost squarely on the local utilities, mostly FE and MISO. The report states that the initiation of the blackout was caused by deficiencies in specific practices, equipment, and human decisions that coincided that afternoon. System operators and reliability coordinators, by NERC policy, have the responsibility and the authority to take actions up to and including emergency generation redispatch and shedding firm load to preserve system security. On August

14, because they either did not know or understand enough about system conditions at the time, system operators at FE, MISO, PJM, or AEP did not call for emergency actions.

According to [1], there were three groups of causes:

**Group 1: Inadequate situational awareness at FirstEnergy Corporation (FE).** In particular:

- FE failed to ensure the security of its transmission system after significant unforeseen contingencies because it did not use an effective contingency analysis capability on a routine basis.
- FE lacked procedures to ensure that their operators were continually aware of the functional state of their critical monitoring tools.
- FE lacked procedures to test effectively the functional state of these tools after repairs were made.
- FE did not have additional monitoring tools for high-level visualization of the status of their transmission system to facilitate its operators' understanding of transmission system conditions after the failure of their primary monitoring/alarming systems.

**Group 2: FE failed to manage adequately tree growth in its transmission rights-of-way.** This failure was the common cause of the outage of three FE 345-kV transmission lines.

**Group 3: Failure of the interconnected grid's reliability organizations to provide effective diagnostic support.** In particular:

- MISO did not have real-time data from Dayton Power and Light's Stuart-Atlanta 345-kV line incorporated into its state estimator (a system monitoring tool). This precluded MISO from becoming aware of FE's system problems earlier and providing diagnostic assistance to FE.
- MISO's reliability coordinators were using non-real-time data to support real-time "flowgate" monitoring. This prevented MISO from detecting an N-1 security violation in FE's system and from assisting FE in necessary relief actions.
- MISO lacked an effective means of identifying the location and significance of transmission line breaker operations reported by their Energy Management System (EMS). Such information would have enabled MISO operators to become aware earlier of important line outages. PJM and MISO lacked joint procedures or guidelines on when and how to coordinate a security limit violation observed by one of them in the other's area due to a contingency near their common boundary.

In this paper we will argue that although the above reasons did indeed cause this particular blackout but the real underlying reason was the systemic lack of coordinated real-time security assessment, information exchange and control. Mistakes, omissions and faults will always happen but a well-designed system should be able to cope with them and localise disturbances.

### **3 Scandinavian blackout on 23 September 2003**

The blackout, which affected about 5 million people in Southern Sweden and Eastern Denmark, has been described in two preliminary reports published by the Danish system operator Elkraft Systems [3], and the Swedish system operator Svenska Kraftnät [4]. In total, 4850 MW of power were lost.

On the day of the blackout some of the transmission links and power stations were down for maintenance but operational planning reflected that and system operated in an apparently reliable manner. At the time Eastern Denmark, which is synchronously connected to Nordic Interconnected Grid, was producing 2,250 MW to cover internal consumption of 1,850 MW and market-governed export of 400 MW to Sweden. The total capacity ready to go into operation was about 3,300 MW so there was ample reserve capacity.

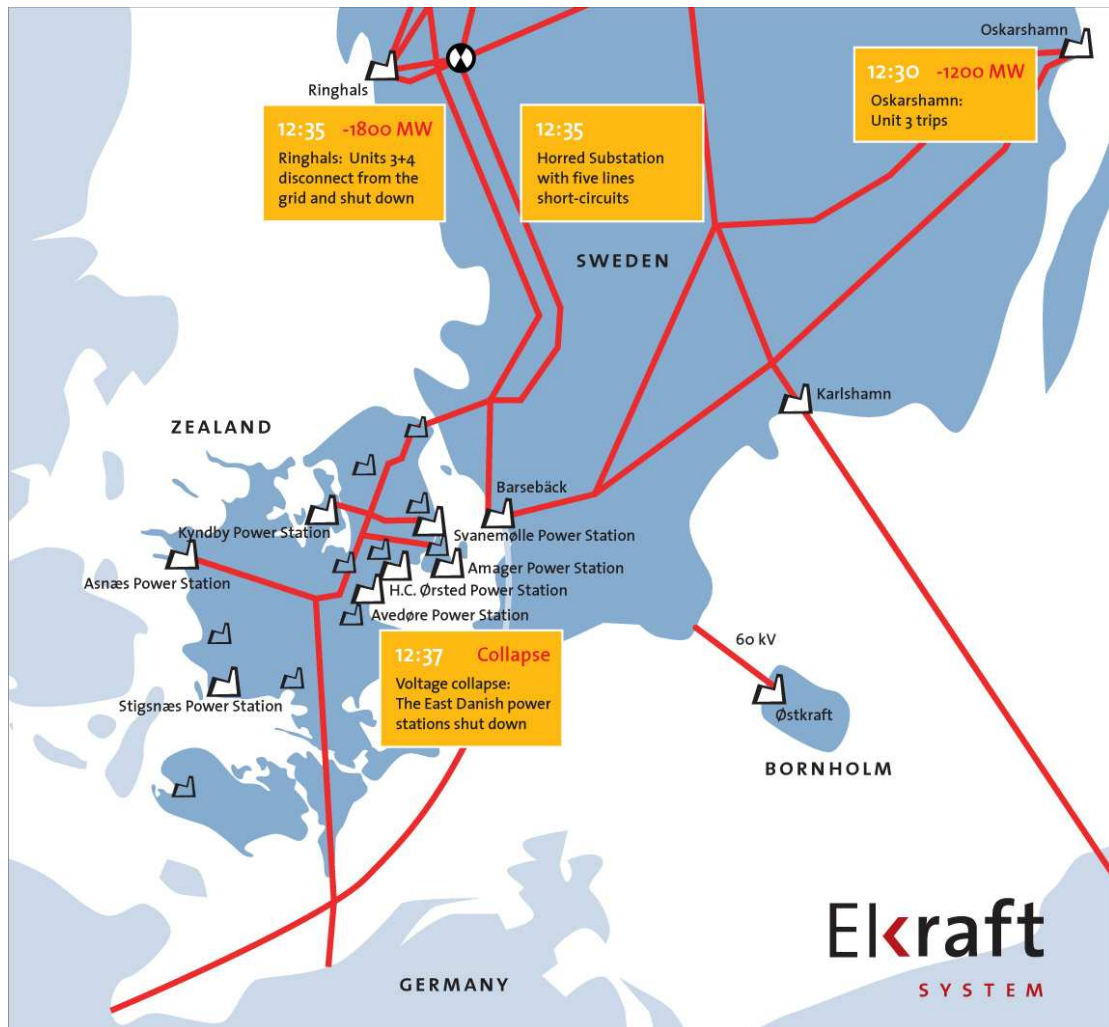

Figure 6. Scandinavian blackout.

### 3.1 Oskarshamn trip

At 12.30 pm 1,200 MW were lost at Oskarshamn nuclear power station in Southern Sweden (see Figure 6) due to problems with a valve in the feed-water circuit. The system reacted to this in a planned way. Loss of generation caused a drop in frequency and this activated an automatic increase of generation in Northern Sweden, Norway, Finland and Eastern Denmark<sup>7</sup>.

<sup>7</sup> This so-called primary frequency control process is explained in Appendix D.

Transmission levels were still contained within the predetermined security constraints. The power flow was however redistributed in the grid due to the loss of generation on the south-eastern side. More power was flowing on the western side to supply the demand in the south. Voltages in the southern part had dropped around 5 kV, but remained within the 405-409 kV level, which is by no means critical. The frequency was automatically stabilised slightly below the normal operating limit of 49.90 Hz, which is normal in the circumstances. Secondary frequency control actions were therefore initiated to raise the frequency – see Appendix D.

### **3.2 Horred substation double-busbar fault**

According to the reliability criteria on which the system is designed and operated, the operator had about 15 minutes in order to restore reliable (N-1) operation by reconfiguring the grid and ordering start-up and ramping-up of other power stations. However just 5 minutes after the first fault, at 12.35 pm, a double busbar fault occurred in a 400 kV Horred substation on the western coast of Sweden. Two 900 MW units in the nuclear power station of Ringhals are normally feeding its output to this substation over two radial lines, connected to separate busbars. The busbars are connected to each other through certain bays, equipped with circuit breakers that are designed to sectionalise and split the substation in order to contain a fault on one busbar and leave the other intact with its connected lines in service. A fault on one busbar should therefore disconnect only one of the two nuclear units.

The reason for the double busbar fault was a damage to one isolator device located in the specific connection bay between the two busbars that the nuclear units were connected to. The isolator is of a type that raises vertically from beneath to contact with the busbar. One of the mechanical joints allowing the structure to move upwards had been disrupted. The circumstances leading to this damage remain to be clarified. The isolator was inspected in March 2003 with respect to thermal overloads but nothing irregular was detected. A similar damage has never been observed in any of the around 70 sets of isolators of this type in the Swedish 400 kV-grid.

The loading current of the isolator had increased from around 1000 A to some 1500 A following the 1175 MW generation loss on the east coast. This is far below its rating for maximum load which is 3100 A. With the joint broken, the vertical structure of the isolator collapsed and it fell to the side in the direction of the other parallel busbar. Falling down, the contact with its own busbar opened with the load current still flowing. This ignited an arc initially between the busbar contact and the isolator parts. Eventually the arc flashed over to the nearest phase of the adjacent busbar. The insulation distance between the busbars was reduced by the protruding parts of the fallen isolator. Supposedly the wind may also have drifted the arc towards the other busbar and helped it to bridge the distance. Through the arc two different phases from the two busbars were short-circuited. This fault was directly detected by the separate busbar protection devices, immediately tripping the circuit-breakers for all incoming lines to both busbars. This is a predetermined action given by the design of the protection system.

### **3.3 System effects**

As a result of the double busbar fault, four 400 kV transmission lines were disconnected. Two of transmission lines connected two units at Ringhals nuclear plant so that further 1750 MW of generation was lost. The other two disconnected transmission lines were a part an important connection between Southern and Central Sweden. Such a severe disruption (combined loss of about 3 GW of generation and two important transmission lines) is extremely rare and is not something any system is designed to handle.

Increased load on the remaining connections between Central and Southern Sweden, aggravated by ramping of generation in Northern Sweden, Norway and Finland to compensate for the lost generation, caused severe voltage decline in Southern Sweden and Eastern Denmark. The existing local reactive power sources were not able to support the voltages. All this was accompanied by power and voltage swings. The frequency dropped to slightly over 49 Hz and under-frequency load shedding schemes started to operate – see Appendix D.

During some 90 seconds after the busbar fault the oscillations faded out and the system seemed to stabilise. Meanwhile the demand in the area recovered gradually from the initial reduction following the voltage drop by action of the numerous feeder transformer tap-changers<sup>8</sup>. This lowered the voltage further on the 400 kV grid down to critical levels. Finally the situation developed into a voltage collapse in a section of the grid south-west of the area around the capital city of Stockholm.

The combination of low voltage and heavy north-south flows were interpreted by protection relays on transmission lines as remote short-circuit (see Appendix B) and they tripped the lines, isolating Central Sweden from Southern Sweden and Eastern Denmark. The isolated part suffered from low voltage and a severe deficit of generation as additional power stations tripped due to power swings and voltage collapse. The voltage fell to zero in about 1 second and Eastern Denmark was then automatically disconnected from Southern Sweden via the zero voltage relays on the Øresund connection.

### **3.4 Conclusions from the Scandinavian blackout**

Elkraft report [3] made the following observations about the blackout:

1. A single mechanical fault in a separator triggered a double busbar fault and resulted in disconnection of four 400 kV lines and two large power station units. There is a need to identify and as far possible remove similar vulnerable points.
2. There is a need to evaluate whether the present protection systems in the power system should be adjusted.
3. There is a need to investigate whether the operational requirements concerning the power stations are sufficient and whether they are met.
4. There is a need to evaluate what measures will make the Danish and the Nordic power system more resistant to major disturbances. The measures could include

---

<sup>8</sup> Feeder transformers supplying distribution lines are often equipped with on-line tap changers which continuously adjust the transformation ratio in order to keep distribution voltages constant. Following the initial voltage drop, tap changers attempted to increase the distribution voltage but that, in turn, reduced the voltages at transmission level (400 kV).



establishment of new power stations, evaluation of the importance of new transmission grids and new protection and control systems, including management of electricity demand.

5. There is a need to evaluate the need for tightening the procedures for communication between the involved parties and communication with the public.

The Scandinavian blackout was the most "technical" of the three, in the sense that it was caused by very rare co-incidence of two very serious faults. However even in that case the report points out to "a need to evaluate the need for tightening the procedures for communication between the involved parties".

## 4 Italian blackout on 28 September 2003.

This section is based on an interim report published by Union for Coordination of Transmission of Electricity (UCTE) [5]. The blackout happened at 3 am when Italy was importing 6651 MW from France, Switzerland, Austria and Slovenia. The import constituted about 24% of total demand and was about 300 MW above the agreed import level. The pattern of flows into Italy through the tie-lines depends on the overall generation pattern in surrounding countries – this is discussed later in section 5.1. At the time, the Swiss transmission grid was highly stressed operating close to (N-1) security criterion. The high usage of Swiss grid by imports to Italy was difficult to control by the Swiss operator by its own means.



Figure 7. Italian blackout [5].

At 3.01 am a tree flashover tripped an overhead 380 kV Mettlen-Lavorgo line in Switzerland – see Figure 7. At the time the loading on the line was about 86% of its maximum capacity and the flashover was probably caused by insufficient distance of the tree from the conductors. An attempt was made to reclose the line but it was unsuccessful due to a too high phase angle difference ( $42^\circ$ ) resulting from a high

power flow to Italy<sup>9</sup>. The load carried by the tripped line was taken over by other parallel lines and resulted in overloading by 10% of another 380 kV line Sils-Soazza – see Figure 7. According to operating standards the line load should have been relieved within 15 minutes to prevent automatic disconnection.

The Swiss operator, ETRANS, telephoned the Italian operator GRTN at 3.11 am and requested reduction of imports by 300 MW to the previously agreed levels. According to ETRANS, they have also informed GRTN about the line outage but this claim is disputed by GRTN. GRTN reduced import at 3.21 am by shutting down pumps at pumped-storage plants but this, together with some internal countermeasures undertaken within the Swiss system, was not sufficient and at 3.25 am, i.e. 24 minutes after the first line tripped, the overloaded Sils-Soazza line sagged and tripped after a tree flashover. From this moment on, a severe system failure was inevitable. Loss of the second import line resulted in a severe overload of other import lines and the third line (Airolo-Mettlen) tripped after 4 seconds. Additionally, Italy lost synchronism with the rest of UCTE (loss of angle stability)<sup>10</sup> and the remaining import lines tripped almost instantaneously isolating Italy from the rest of Europe at 3.25 am. Quite importantly, the dynamic interaction between the Italy and rest of UCTE main grid during the last seconds before separation led to a fast voltage collapse in Italy. Following islanding of Italy, the internal generation deficit was about 6.4 GW and frequency started to fall – see Appendix D. Although about 10 GW of load was shed by automatic under-frequency load shedding, it proved ineffective as 21 out of 50 thermal plants were tripped due to low voltage<sup>11</sup> even before frequency reached 47.5 Hz - see Figure 8. Consequently the whole Italy, apart from Sardinia, was blacked out 2 minutes and 30 seconds after separation.

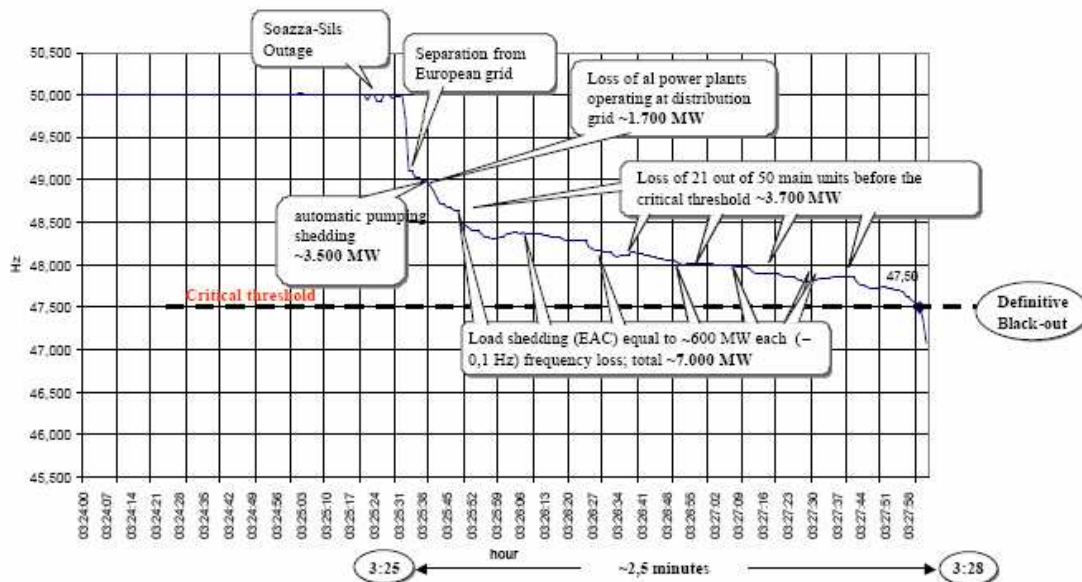

Figure 8. Frequency in Italy [5].

Following separation of Italy, the rest of UCTE network was also in a dangerous position. Frequency quickly increased to 50.25 Hz, significant power fluctuations

<sup>9</sup> See Appendix E for the explanation what phase angle is and how it is related to a power flow.

<sup>10</sup> See again Appendix E.

<sup>11</sup> See Appendix C for the reasons why generators trip off.

were recorded – see Figure 9 - and the European power flows took an unpredicted pattern. Some generating units were tripped by over-frequency or under-voltage relays. Loading of lines from France to Germany and Belgium increased significantly. However the system operators took various emergency actions so that further spreading of blackouts was avoided.

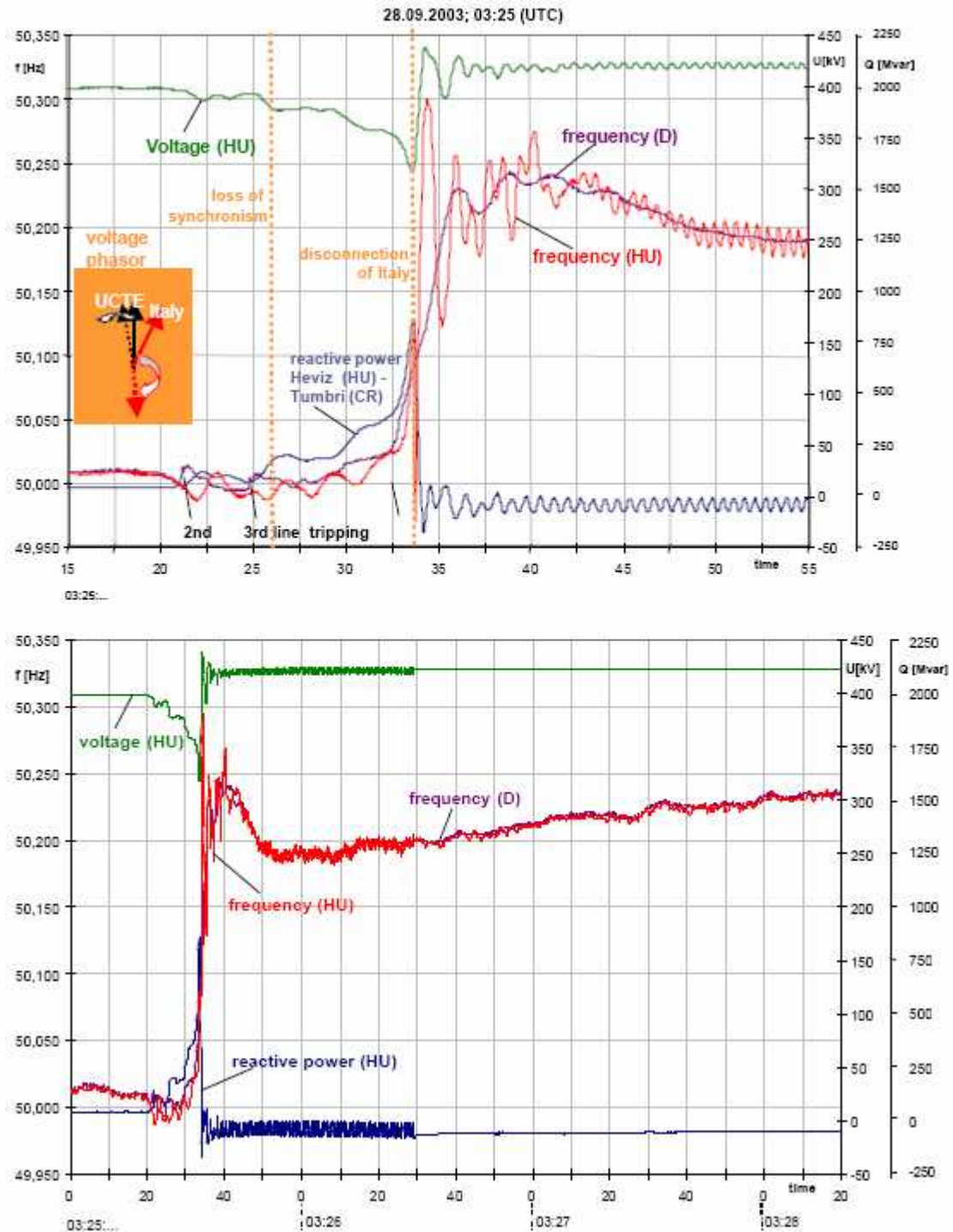

Figure 9 Frequency, voltage and and reactive power in Heviz (Hungary) and frequency in Uchtelfangen (Germany) [5].

## **4.1 Conclusions from the Italian blackout**

Similarly as it was the case of the US blackout, the real underlying reason for such a widespread blackout was insufficient coordination of real-time security assessment and control between the TSOs. Additionally Italian system operator was unaware of the overall load flow situation in Europe and the resulting consequences for Italy.

The interim UCTE report concluded that the root causes for the blackout were:

- Unsuccessful reclosing of Mettlen-Lavorgo line due to a too high phase angle difference
- Lacking sense of urgency regarding the overloaded Sils-Soazza line and call for countermeasures in Italy. The Swiss operators were unaware that that the overload was sustainable for only 15 minutes.
- Angle instability and voltage collapse in Italy which prevented a successful island operation in Italy. The investigating committee made it clear that these phenomena and its severe consequences could not have been foreseen according to the state of the art and the operational experience in UCTE.
- possibly insufficient right-of-way maintenance practices (tree cutting)

The report also concluded that in Europe, where the network is highly meshed and stability problems never appeared to be so critical, power system stability must be thoroughly analysed - even in the case of N-2 contingencies. This will require deeper stability analyses, in order to identify possible conditions leading to stability problems and to define suitable countermeasures if necessary.

## **5 Lessons from the blackouts: is liberalisation to blame?**

It is quite striking that all three blackouts happened at the boundaries between systems in interconnected network, when transmission failures interrupted bulk inter-area trades. Additionally, in the case of US and Italy, the events were allowed to spread due to insufficient coordination between system operators. Is it therefore liberalisation (called deregulation in the US) to blame? To answer that question we will have to step back and look at the developments over the last 50-60 years. Historically, the utilities serving their native load (countries in Europe) tended to be self-sufficient, i.e. generation matched demand. This resulted in well developed internal transmission networks but relatively weak tie-lines linking neighbouring networks. Over time the networks started to be increasingly interconnected but those connections were never intended to be used for bulk cross-border trades. Rather, the main motivation was in providing support to each other in terms of sharing reserve, providing better frequency response<sup>12</sup>, and coordinated power exchanges. The operational procedures evolved around that model where each TSO looked after their own networks, agreed power exchanges well in advance and communicated with each other by phone in emergency. This well ordered world changed with the advent of liberalisation but, unfortunately, the mode of operation and coordination has not changed much.

---

<sup>12</sup> The bigger the interconnected system, the smaller frequency drop due to a loss of a power station – see Appendix D.

## 5.1 Parallel flows

One of the main problems with cross-border trades in an interconnected power system is that trades do not travel according to agreed "contract paths" but rather flow over many transmission lines, as determined by Kirchhoff's and Ohm's laws. This is referred to as a parallel, or loop-flow, effect. Consequently utilities find their networks loaded with power transfers they have little idea about. Figure 10 shows different routes through which an assumed 1000 MW trade between Northern France and Italy would flow [6]. Only 38% of power would flow directly from France to Italy; the remaining 62% would flow through different parallel routes loading the transit networks. Note that 15% of power would even flow in a round way via Belgium and Netherlands.

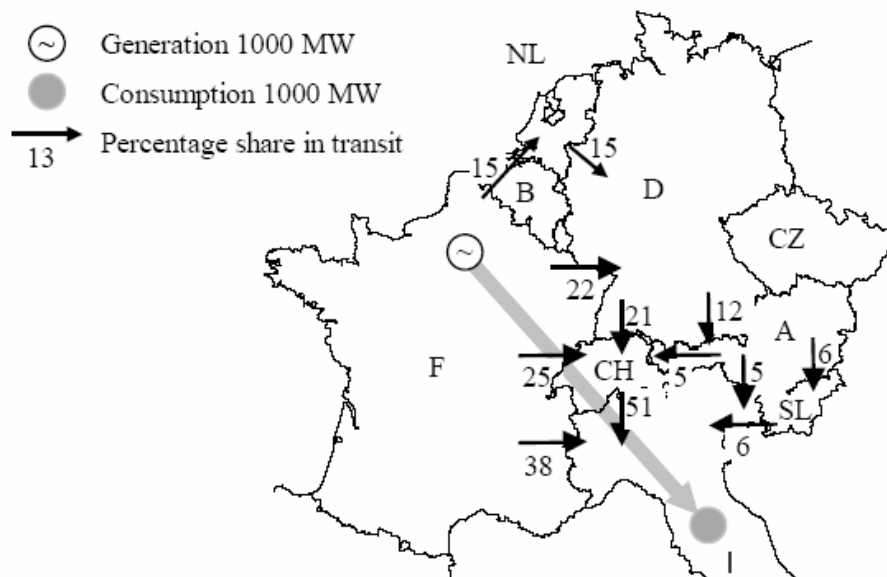

Figure 10. Percentage shares through different transit routes for a trade from northern France to Italy [6].

Parallel flows did not cause major problems pre 1990, as inter-area exchanges were usually agreed well in advance by the system operators and were relatively small. Post 1990, inter-area trades have not only increased significantly in volume, but they also started to be arranged by independent agents, rather than system operators. The result may be as that shown in Figure 11 [7], when a large proportion of flows on the Belgian grid in 1999 was unexpected by the Belgian system operator. That situation led to a few nearly avoided blackouts in Belgium in 1990s.

A similar parallel flow effect was one of the main factors contributing to US and Italian blackouts. In the case of US, as the existing transmission corridors were increasingly blocked by lines tripping off, power to supply northern Ohio and Ontario had to find alternative ways and did so through neighbouring utilities (Michigan, PJM and New York) – see Figure 2. The relevant system operators suddenly saw huge increases in power transfers through their territories but they did not know what caused them and could do little about them.



In the case of Italian blackout, transfers through Switzerland to Italy depended on the overall pattern of generation in surrounding countries. Although some of Swiss lines were operating close to their limits, Swiss operators could do little to relieve them.

Proper accounting for parallel flows is difficult enough in operational planning stages. In emergencies, when power system topology may be different to the assumed one and some power stations may be lost, proper accounting for parallel flows would require real-time security monitoring and automatic exchange of information between TSOs, rather than telephone-based coordination.

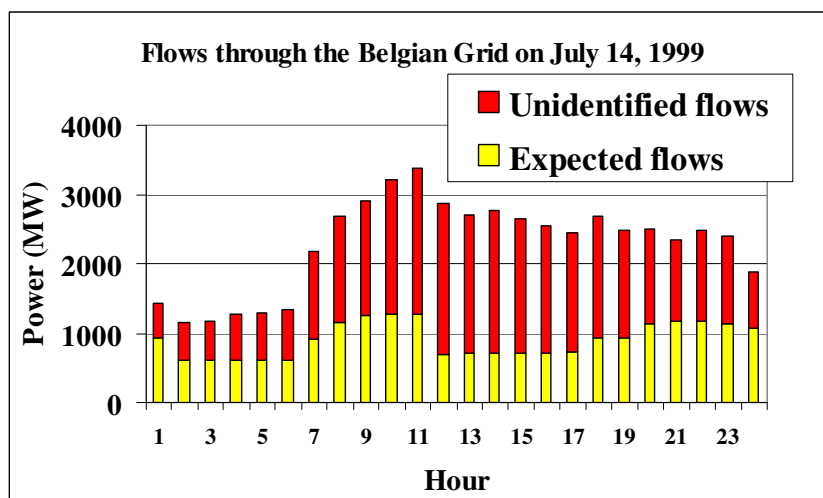

Figure 11. Expected and unidentified flows through Belgian grid [7].

## 5.2 Reduced security margins

Increased and often unexpected inter-area flows have detrimental effect on system security. Until 1990's, system operators tended to maintain conservative security margins as the commercial pressures were not that strong and the main concern was "to keep the lights on". With the advent of liberalisation, commercial pressures have pushed system operators to run transmission systems closer to their limits. In the US, the number of daily transactions has grown by roughly 400% since 1998 [2]. The impact of those transactions on transiting utilities can often be unaccounted for due to the parallel flow effect, as discussed in the previous sub-section. In Europe cross-border trades are also increasing in volume due to the creation of Internal Electricity Market. At the time of blackout, Italy was importing nearly a quarter of its demand putting a significant stress on the interfaces. With the increased stress on transmission systems, and the largely unchanged mode of co-operation between the TSOs, security margins shrunk and the probability of blackouts increased.

## 5.3 Main culprit: insufficient real-time co-operation

In the old pre-1990 world, vertically-integrated utilities looked after its own area and operated with wide security margins. This can be described as a decentralised control

mode with no central body coordinating real-time operation, security assessment and control. The basic assumption behind that approach was that there was little interaction between control areas. In the operation planning stage, inter-area (or cross-border) exchanges were agreed and the utilities were supposed to keep to them. When a contingency disturbed the balance of power, e.g. due to a loss of a power plant, TSOs were able to maintain their agreed exchange schedules by monitoring Area Control Error (see Appendix D), i.e. without a need to communicate explicitly with each other. If a contingency threatened system security, system operators would pick up phones to inform each other and agree the course of action. This was generally satisfactory due to maintaining large security margins but is no longer satisfactory now. With the increased level of interaction, the decentralised and weakly coordinated mode of operation is simply not adequate.

The main thesis of this paper is that the main underlying reason for the recent blackouts was the lack of real-time coordination, security assessment and control. Specific "root causes" as identified in reports [1, 3, 4, 5] did indeed cause those particular blackouts but faults, mistakes and malfunctions will always happen. Well designed system should deal with those contingencies without causing large-scale failures. However the existing phone-based mode of co-operation is simply too slow compared with the time-frame of dynamics involved. By the time an operator picks up the phone to inform about an outage or overload, waits for the other person to answer, and says "How are you?" it may be too late to do anything. This is what happened during both the US and Italian blackouts. None of the system operators had real-time information of the status of, or power flows through, important regional lines outside their own control areas.

The conclusion is therefore that it is not liberalisation as such to blame. It is rather that the utilities did not seem to have adjusted to the new situation. Quite simply old solutions which worked reasonably well in the good old world of monopolistic and vertically integrated utilities cannot be used in the new liberalised world. New paradigm of operation is needed which would resolve the problem of appropriate coordination and real-time exchange of information, security assessment and control.

Of course it is easier said than done. It is important to appreciate that the challenge is mainly political, rather than technical. The technical infrastructure to implement the advocated above coordination is generally available, but the main problem is in overcoming the often parochial attitudes of traditional utilities. To realise the scale of the problem recall that the Northern American system consists of three interconnections and over 140 utilities shown in Figure 12. The situation is further complicated by the "Swiss cheese" situation in which RTOs or ISOs are often responsible for geographically not-contiguous areas and their responsibility are overlapping, as was the case of Midwestern US system shown in Figure 1. The situation in Europe is perhaps not as bad but still the western continental Europe consists of two main interconnections with many countries involved. What makes communication worse in Europe is that generally each country speaks a different language.

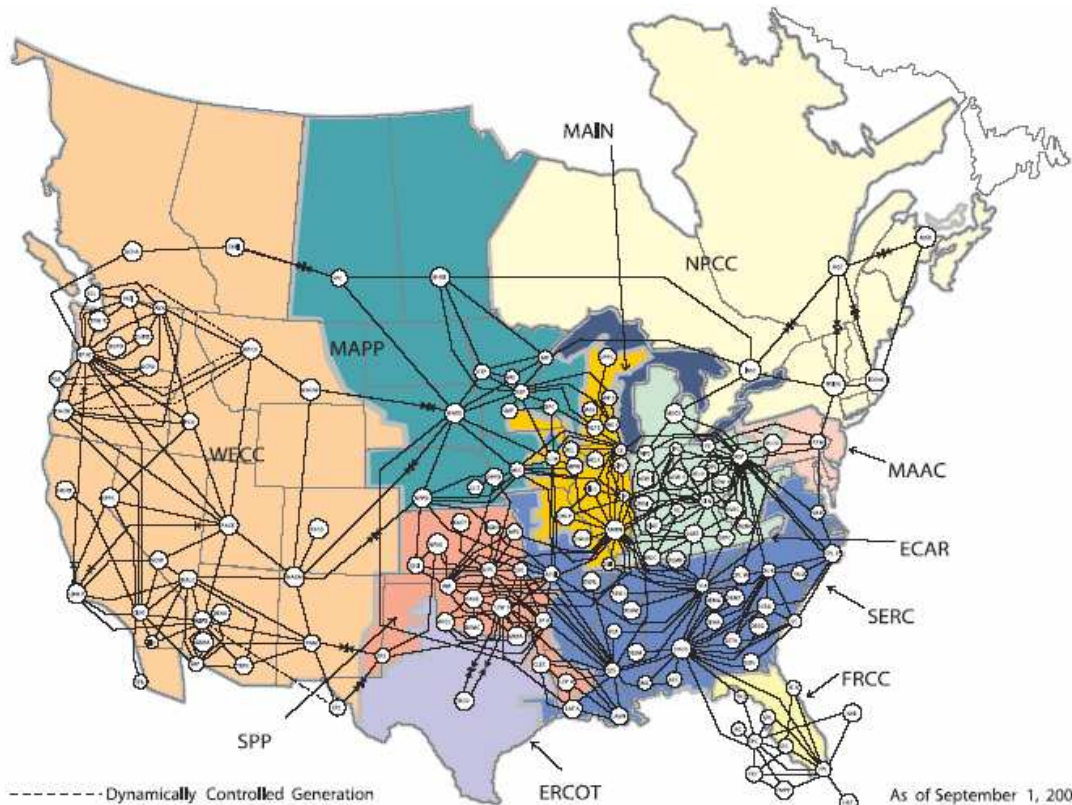

Figure 12. US system consisting of 3 interconnected areas, 10 reliability councils and about 140 control areas controlled by ISOs or RTOs [1].

#### **5.4 Organisational and political challenge: move from decentralised to coordinated real-time security assessment and control**

The simplest solution to the problem of coordination would be to set up a single transmission system operator (TSO) for each interconnection. Such solution is however probably politically unacceptable and it is also not clear that it would be technically feasible for such a mammoth TSO to control the whole interconnected network. Hence a new mode of operation has to be found which would preserve existing independence of utilities and yet provide required cooperation. Many steps have already been taken in that direction. In the US, NERC and FERC are trying to introduce changes in the way systems are operated by creating RTOs. Also UCTE has undertaken a number of steps in the same direction, introducing for example a system of information exchange DACF (Day Ahead Congestion Forecast). However more is needed in order to achieve an efficient system of real-time information exchange and security assessment.

Probably the best way forward is to change the paradigm of operation from the existing decentralised to the coordinated one in which each TSO would still look after its own area in day-to-day operation and planning but necessary coordination would be required for system-wide security assessment and control purposes. A similar approach has been advocated in [9]. To do that information would have to be exchanged to assess the impact of planned trades on all the areas involved or, in other words, to assess accurately all the parallel flows in both operational planning and real-

time operation stages. Furthermore, real-time coordinated security assessment would be needed to assess the impact of any contingencies on the whole interconnected network. Obviously this would have to be done in a fully automatic way, without a necessity to use a phone. The next step is to coordinate reaction to contingencies. When each TSO defends itself against a contingency without taking into account the big picture, the results may be detrimental for the system as the whole. The next important problem is determination of who, and how much, should pay for the reliability-connected actions.

There are many challenges in moving to the new paradigm of coordination. Probably the main one is convincing the utilities involved to give up a part of their independence. One of the other main problems with increased coordination is the necessity to exchange operational information about each control area. Such information could be deemed to be commercially sensitive so the TSOs would be reluctant to share it. Traditional load-flow or stability programs require detailed information about generation and demand profiles at each node but for proposed coordinated operation and control exchange of full individual nodal profiles is not needed. The important thing is to assess the system-wide impact of situation in each control area. Further research is needed to establish what type of information is necessary to be exchanged, and in what way, in order to perform system-wide security assessment and control whilst which information can be deemed to be left as private to individual TSOs. Following that, appropriate organisational structures will have to be established. There may be a need to establish a single body charged with maintaining real-time security of the whole interconnected system. Obviously establishing that new coordinated structure would require solving significant legal, organisational, and technical problems. However it is important to understand that to maintain the status quo means either running the system very conservatively, maintaining large security margin at a high cost to everyone, or another blackout, sooner or later.

## **5.5 Technical challenges**

Once the organisational and legal challenges described above have been resolved, there are a number of technical challenges to be solved as well. In this section examples of a few most important ones will be outlined.

The recent blackouts have shown that the current arrangements for decoupling real and reactive power provision (voltage support) seem to be inadequate, especially in emergency state. Voltage collapse in all three blackouts considered was caused by increased transmission distances and inadequate local provision of reactive power. Trading arrangements usually deal only with provision of real power while reactive power provision tends to be solved through some ad hoc arrangements under a broad label of "ancillary services". Often Independent Power Producers are not required to provide reactive power at all – see Appendix A. Again a new paradigm is needed so that the problem of coordinated provision of adequate reactive power is solved.

Existing congestion management protocols are often based on Power Transfer Distribution Factors (PTDFs) which are calculated using simplified dc network model and neglect line loading due to reactive power flows. This approach is generally

satisfactory during normal operation but may yield unacceptable errors during emergencies when increased real power flows cause increased reactive power losses.

US and Scandinavian blackouts have shown that protection can contribute to the catastrophic failures. In both cases, lines were tripped by back-up distance relays which perceived lowered voltage and increased power transfers as remote short-circuits. Research effort is needed in order to provide a more selective operation of those and other relays. Ideally, relays should be adaptive in order to distinguish whether the system is in a secure state or in an emergency [8]. When the system is in a secure state and can cope with contingencies, the main danger for system security is if the faults are not cleared quickly enough. The main emphasis of protection is then on dependability, with the primary protection backed up by secondary protection. The price one pays for that dependability is occasional unnecessary tripping of devices. However in the healthy system state such over-tripping is not harmful as the system can cope with it. On the other hand, when the system is stressed, over-tripping may be very harmful indeed as it increases the system stress even more. Hence one would prefer to reduce the risk of false trips and accept a reduction in dependability as this would increase system security.

Another problem is how to include system stability in (N-1) security rule. Usually, the maximum loading on transmission lines is determined by taking into account thermal limits. Italian blackout showed the importance of angle stability. Stability analysis has to be undertaken using the whole system model, hence once again underlying the importance of real-time exchange of information and security assessment.

All the proposed changes outlined above require significant research in the areas of hierarchical control of complex systems and supporting IT. Also new market arrangements would probably need to be developed, especially regarding provision of reactive power, generation reserve, and transmission reserve. Generally speaking, provision of system security has to be properly incentivised and charged to the users endangering it.

## **6 Fallacy: transmission investment will prevent blackouts.**

Whenever a blackout happens, a typical knee-jerk reaction of some people is to blame underinvestment in transmission networks. A good example of that was the former US Secretary of Energy Bill Richardson who, in response to US blackouts, was quoted to say "...we are a superpower with a Third-World grid..". Although figures do show that current investment in the US grid lags behind historical numbers, it is not the level of investment that determines vulnerability of a grid to blackouts but rather the operational rules [10]. Of course an underinvested grid suffers from congestion and bottlenecks but it is still perfectly possible to operate it in a secure way. Conversely, well developed grid may be vulnerable to blackouts if it is operated in an insecure way.

To understand why transmission investment does not, on its own, prevent blackouts in the long term consider what happens when investment relieves some of transmission bottlenecks. Situation will not remain static but generating companies will try to take



advantage of new opportunities created by grid enhancement and try to expand too by, for example, constructing new plants where there is access to cheap primary fuels and transmit energy to main demand centres. This will continue until, after some time, the grid will reach its limits again, although at a higher level. Of course, transmission investment is needed but its main aim is to reduce both prices (by allowing access from cheaper generation) and market power (by increasing local competition). Constructing new transmission lines does have some long-term effect on reliability by increasing the number of parallel connections but having appropriate operating rules is more important for prevention of blackouts. This was put succinctly by M. Gent (NERC) when he commented on US blackout: "...either the rules were not followed or the rules were not adequate..". The main point of this paper is to argue that although some rules may have not been followed, the main underlying reason for the blackouts was that the rules were not adequate as they did not take into account the increased market liberalisation and shrunk security margins.

## 7 Conclusions

The recent blackouts in the US and continental Europe have exposed a number challenges facing TSOs worldwide. The increased liberalisation of electricity supply industry has resulted in a significant increase in inter-area (or cross-border) trades which often are not properly accounted for when assessing system security. The traditional decentralised way of operating systems by TSOs, with each TSO looking after its own control area and little real-time information exchange, resulted in inadequate and slow response to contingencies. A new mode of coordinated operation is needed in order to maintain system security. This new mode of operation requires overcoming a number of organisational, psychological, legal and technical challenges but the alternative is either to risk another blackout, sooner or later, or run the interconnected system very conservatively, maintaining large security margin at a high cost to everyone.

## 8 References

1. US-Canada Power System Outage Task Force "Interim Report: Causes of the August 14<sup>th</sup> Blackout in the United States and Canada" November 2003.
2. EPRI: "Factors Relating to the Series of Outages on August 14, 2003. A White Paper" November 20, 2003.
3. Elkraft Systems "Power failure in Eastern Denmark and Southern Sweden on 23 September 2003. Preliminary report on the course of events" 2 October 2003
4. Svenska Kraftnät: "The black-out in southern Sweden and eastern Denmark, 23 September, 2003 Preliminary report" 2 October 2003.
5. UCTE: "Interim Report of the Investigation Committee on the 28 September 2003 Blackout in Italy" 27 October 2003.
6. H.-J. Haubrich, W. Fritz: "Study on Cross-Border Electricity Transmission Tariffs by order of the European Commission, DG XVII/C1" Aachen, April 1999.
7. P. Bonnard: "Power System Collapse: European Utility Experience" 2003 IEEE Trans. Distr. Conf.
8. S. H. Horowitz, A. G. Phadke: "Boosting Immunity to Blackouts" IEEE Power and Energy, Vol. 1, No. 5, September/October 2003.

9. M. Ilić: "Technological and Management Structures to Support Reliable and Efficient Operation over a Broad Range of Generation and Demand" November 15, 2003.
10. D. Kirschen and G. Strbac: "Why investments do not prevent blackouts" UMIST, 27 August 2003. A. J. Wood,
11. B. F. Wollenberg: "Power Generation, Operation, and Control", Wiley, 1996.
12. J. Machowski, J. W. Bialek, J. R. Bumby: "Power System Dynamics and Control", Wiley, 1997.

# TECHNICAL APPENDICES

## APPENDIX A: REACTIVE POWER PRIMER

All the temporary power systems are ac, i.e. currents and voltages are sinusoidal. Product of instantaneous voltage and current is power and mathematical analysis reveals that instantaneous power can be broken down into two components, referred to as real (or active) power  $P$  and reactive power  $Q$ . Power factor is defined as  $P / \sqrt{P^2 + Q^2}$ .

Real power  $P$  is always positive (i.e. unidirectional) so it represents a useful work (heating, lighting, moving engines etc.) done by electricity. Reactive power  $Q$  is oscillating around zero axis, so its average is zero. In other words, reactive power corresponds to energy which is sent back and forth between the source and the load and cannot be used to do any useful work. Reactive power can be inductive or capacitive. Inductive reactive power is necessary to provide energy to magnetise coils of any electrical machine connected to the system. Capacitive reactive power is necessary to provide energy to charge any capacitor. The reason inductive reactive power oscillates between the source and the load is that any coil is magnetised, and then demagnetised, twice every electric cycle. Similarly, capacitive reactive power oscillates because capacitors are charged, and the discharged, twice a cycle.

### Reactive power sinks and sources

Capacitive reactive power is directly out of phase with respect to inductive reactive power. This means that inductive and capacitive reactive power compensates each other. Common convention is to assume that a capacitor is the "source" of reactive power while an inductor, such as e.g. induction motor, is a "sink" of reactive power. According to the law of preservation of energy, reactive power "produced" in a system must be equal to reactive power "consumed".

Most of power system loads are inductive, due to widespread use of induction motors, so they consume reactive power. The main sources of reactive power are synchronous generators. The amount of reactive power produced, or consumed, by a generator can be varied by the excitation control<sup>13</sup>.

Equivalent circuit of a transmission line contains both inductances and capacitances. A line may be net-capacitive, i.e. producing reactive power, when its loading is below so-called natural load. A line becomes net-inductive, hence consuming reactive power, when its loading increases above the natural load. There are also many reactive power compensators in the system which help maintaining reactive power balance such as fixed capacitors, fixed inductors, Static Var Compensators (SVCs), and different Flexible AC Transmission System (FACTS) devices [12].

### Reactive power and thermal limits

---

<sup>13</sup> Generally speaking a synchronous generator consists of two windings: ac armature winding and dc excitation (or field) winding. Load current flows through the armature winding while excitation control determines the dc field (or excitation) current necessary to maintain a specified voltage at the generator terminals.

Reactive power has a number of undesirable effects for power system operation. Firstly, as reactive power travels back and forth between the sources and the loads, it causes transmission losses on generation and transmission devices. This is the main reason why industrial users are encouraged by appropriate tariffs to operate at unity power factor by installing their own reactive power compensators.

Transmission losses due to reactive power flows show themselves as heating so that less room is left for real power generation and transmission, before thermal limits are hit. This effect is especially prominent during heavy power transfers. Normally transfer capacities of transmission lines are calculated using only real power<sup>14</sup>. This is acceptable during normal system operation but emergencies may result in heavy power transfers which, as explained above, result in transmission lines consuming large amounts of reactive power. That reactive power loads up additionally transmission lines speeding up the tripping by protective devices.

### **Reactive power and voltage**

Flow of both real and reactive power results in voltage drops, i.e. voltage at the receiving end of transmission line is lower than the voltage at the sending end<sup>15</sup>. However typically reactive power flows cause 5-10 times higher voltage drops than real power flows<sup>16</sup>. Another way of saying that is that reactive power tends to travel from a higher voltage to a lower voltage. Hence there is an almost direct proportionality link between reactive power and voltage, i.e. high reactive power consumption and transfers results in depressed voltages and vice versa. It may even happen that at night, when real and reactive power demand is low, power transfers are below natural loading of transmission lines. Transmission lines may then become net sources of reactive power so that system voltages rise up. To keep voltages down, it may be then necessary to reduce excitation of synchronous generators or switch on additional reactors to consume the excess of reactive power.

Because of the strong link between reactive power and voltage, reactive power compensation is often also referred to as voltage support.

Reactive power losses, i.e. reactive power consumption, in typical transmission lines and transformers are about ten times higher than real power losses. Consequently it is impossible to transfer large amounts of reactive power over long distances as that would require large voltage differences in the system<sup>17</sup>. To avoid large reactive power transfers, consumers are encouraged, through tariffs, to cover their own reactive power requirements while utilities install different types of compensators to manage voltage profiles.

---

<sup>14</sup> Power Transfer Distribution Factors (PTDFs) commonly used to evaluate the amount of power flowing in a given line due to a given transaction are calculated using so-called dc network model which neglects all reactive power effects.

<sup>15</sup> This is assuming that the flow of real and reactive power is in the same direction. It may happen that the flow of real power is in the opposite direction than the flow of reactive power. Then the voltage at the receiving end (with respect to real power flow) may be higher than the sending end voltage.

<sup>16</sup> This is true at transmission level. In distribution networks voltage drops due to real and reactive power flows may be comparable.

<sup>17</sup> There are very strict limits about how much voltage can differ from its nominal value. In the UK, transmission voltages have to be kept within  $\pm 10\%$  of their nominal value.

The strong link between reactive power and voltage explains why voltage collapsed during recent blackouts. When transmission lines were tripping in a domino-like effect, the loading on the remaining lines increased. As reactive power consumption of a transmission line is approximately proportional to the current squared, reactive power consumption of two parallel, equally loaded, lines is about half of that of a single line carrying the same total load. Hence as fewer and fewer lines were carrying the same load, the overall consumption of reactive power increased. This increased reactive power consumption resulted, in turn, in increasingly depressed voltages as shown in Figure 3.

Increased reactive power demand may lead to a voltage collapse when the system loading exceeds certain critical loading. Voltage collapse is characterised by a self-sustained continuous reduction in voltage despite being enough real power generation in the system to cover demand. There were a number of voltage collapses in the 80's, most notably in Japan and France.

### **Independent Power Producers and Reactive Power**

Reactive power/voltage effects are highly non-linear and not easy to understand. Under the old regime of vertically integrated utilities, reactive power and voltage problems tended to be solved in-house in an integrated way. Liberalisation forced "unbundling" of services but attempts to incentivise properly provision of reactive power have been often unsuccessful. Electricity markets tend to deal mostly with real power so that reactive power problems, treated as part of "ancillary services", are often covered by ad hoc arrangements. For example Independent Power Producers (IPPs), i.e. power plants that are not owned by utilities, are interested in providing real power only, because this is what they are mainly paid for. Under routine contract conditions with local utilities, some IPPs provide only limited reactive power because they are not required or paid to produce it<sup>18</sup>. Some contracts, however, compensate IPPs for following a voltage schedule set by the system operator, which requires the IPP to vary its output of reactive power as system conditions change. Further, contracts typically require increased reactive power production from IPPs when it is requested by the control area operator during times of a system emergency. In some contracts, provisions call for the payment of opportunity costs to IPPs when they are called on for reactive power (i.e., they are paid the value of foregone active power production).

Some observers suggested that IPPs may have contributed to the difficulties of reliability management on August 14 because they don't provide reactive power. Report [1] argues that such accusation is misplaced. What the IPP is required to produce is governed by contractual arrangements, which usually include provisions for contributions to reliability, particularly during system emergencies. More importantly, it is the responsibility of system planners and operators, not IPPs, to plan for reactive power requirements and make any short-term arrangements needed to ensure that adequate reactive power resources will be available.

---

<sup>18</sup> Generation of reactive power by a generator can require scaling back generation of active power. This is due to additional heating of generator circuits when reactive power is produced.

### **Was the US blackout a voltage collapse?**

Report [1] argues that the northern Ohio electricity system did not experience a classic voltage collapse because low voltage never became the primary cause of line and generator tripping. Although voltage was a factor in some of the events that led to the ultimate cascading of the system in Ohio and beyond, the event was not a classic reactive power-driven voltage collapse. Rather, although reactive power requirements were high, voltage levels were within acceptable bounds before individual transmission trips began, and a shortage of reactive power did not trigger the collapse. Voltage levels began to degrade, but not collapse, as early transmission lines were lost due to tree-flashovers. Soon, in northern Ohio, lines began to trip out automatically on protection from overloads, rather than from insufficient reactive power. As the cascade spread beyond Ohio, it spread due not to insufficient reactive power, but because of dynamic power swings and the resulting system instability. Voltage collapse in some areas was a result, rather than a cause, of the cascade. Significant voltage decay began after the system was already in emergency following a number of line trips.

Report [1] points out that relative voltage levels across the northeast affected which areas blacked out and which areas stayed on-line. Within the Midwest, there were relatively low reserves of reactive power, so as voltage levels declined many generators in the affected area were operating at maximum reactive power output before the blackout. This left the system little slack to deal with the low voltage conditions by ramping up more generators to higher reactive power output levels. In contrast, in the northeast—particularly PJM, New York, and ISO-New England—operators were anticipating high power demands on the afternoon of August 14, and had already set up the system to maintain higher voltage levels and therefore had more reactive reserves on-line in anticipation of later afternoon needs. Thus, when the voltage and frequency swings began, these systems had reactive power already or readily available to help buffer their areas against a voltage collapse without widespread generation trips.

### **APPENDIX B: WHY THE LINES TRIP OFF**

Any transmission line heats up proportionally to the current squared – the corresponding energy loss is referred to as the transmission loss. As a conductor heats up, it increases its length so the line sags and may touch a tree growing underneath it (so-called tree flashover). Normal rating of the line reflects the maximum continuous current that does not heat up the line to above 90°C. A line can carry a higher current during an emergency but only over a short period of time before it heats up excessively.

The US and Italian blackouts were triggered by lines sagging due to high load and coming in contact with trees. Protection devices tripped the lines in order to protect them from the effects of high short-circuit currents. Once a line was tripped, the loading on all the other lines in the area was increased, as the other lines had to take up the load of the tripped line, and outages propagated in a domino-like cascading effect. However some of the lines unnecessarily tripped due to protective impedance (also called distance) relay action. Impedance relays protect transmission lines by measuring apparent impedance, i.e. ratio of voltage and current. Any short-circuit



depresses voltage and increases current in the surrounding lines. At the point of fault the voltage is very low (zero for a three-phase short-circuit) and the current is very high, so the measured impedance is very small. As the distance from the point of fault increases, the voltage increases too while current decreases, so that the measured impedance increases. Hence apparent impedance is a measure of how far the fault is from the relay.

A distance relay is usually installed at each end of a transmission line. Unfortunately, the measurement of the apparent impedance has low accuracy. Consequently the relay must have a time characteristic with a few zones, usually three, corresponding to different impedance settings and tripping times, as shown in Figure 13 [12]. Distance protection (marked by the small solid rectangle) of line *A-B* at busbar *A* has three zones,  $Z_{A1}$ ,  $Z_{A2}$  and  $Z_{A3}$ , with tripping times  $t_1$ ,  $t_2$  and  $t_3$ , respectively. To make sure that a distance relay will not over-reach the protected zone, i.e. unnecessarily trip for faults outside the zone, the first protection zone  $Z_{A1}$  is usually set at between 85% and 90% of the line length. As this first zone can not protect the entire line the distance relay is equipped with a second zone,  $Z_{A2}$ , which deliberately reaches beyond the remote terminal *B* of the transmission line. The second zone  $Z_{A2}$  is slowed down in order that, for faults in the next line section (*B-C*), the first-zone relay of the next line (with setting  $Z_{B1}$  located at *B* in section *B-C*) will operate before the second zone  $Z_{A2}$  of the distance relay at *A*. The second zone of *A* also partially backs up the distance relay of the neighbouring line. In order to provide a back up of the entire neighbouring line, there is usually yet another zone,  $Z_{A3}$ , for the relay at *A*, extending to about 150% of the next line section. The third protection zone is obviously the slowest and its aim is to trip the line if there was a fault in the neighbouring line which was not cleared by that line's protection.

The third zone can cause problems because it has the highest impedance setting so it may be difficult to differentiate between an actual remote short-circuit and an abnormal high loading. This is illustrated in Figure 14 for one of the lines tripped on August 16. The point of trip was just inside the third zone of the relay. Although the relay operated as it was designed to do, it was unable to distinguish between a genuine fault and abnormal high load conditions.

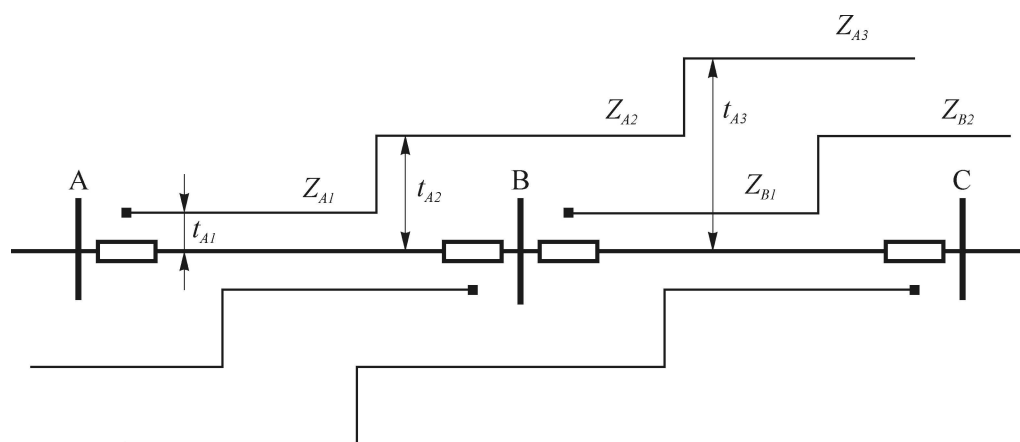

Figure 13. Distance protection zones of two neighbouring lines.

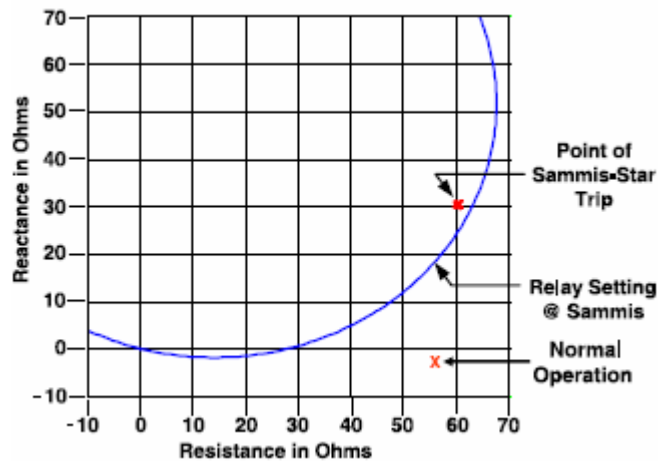

Figure 14 Distance relay characteristic of Sammis-Star 345 kV line [1].

Report [1] points out that on August 14, the cascade became a race between the power surges and the relays. The lines that tripped first were generally the longer lines, because the distance relay settings use a longer apparent impedance tripping zone, which a power swing enters sooner, in comparison to the shorter apparent impedance zone targets set on shorter, networked lines. On August 14, relays on long lines that were not highly integrated into the electrical network, tripped quickly and split the grid between the sections that blacked out and those that recovered without further propagating the cascade. This same phenomenon was seen in the Pacific Northwest blackouts of 1996, when long lines tripped before more networked, electrically supported lines. The vast majority of trip operations on lines along the blackout boundaries between PJM and New York (for instance) show high-speed relay targets, which indicate that massive power surges caused each line to trip. To the relays, this massive power surge altered the voltages and currents enough that they appeared to be faults. This power surge was caused by power flowing to those areas that were generation-deficient. These flows occurred purely because of the physics of power flows, with no regard to whether the power flow had been scheduled, because power flows from areas with excess generation into areas that are generation-deficient.

### APPENDIX C: WHY THE GENERATORS TRIP OFF [1]

At least 263 power plants with more than 531 individual generating units shut down in the August 14 blackout. There were three categories of generator shutdowns:

1. Excitation system failures during extremely low voltage conditions on portions of the power system
2. Plant control system actions after major disturbances to in-plant thermal/mechanical systems
3. Consequential tripping due to total system disconnection or collapse.

Examples of the three types of separation are discussed below.

**Excitation failures.** The Eastlake 5 trip at 1:31 p.m., which started the blackout, was an excitation system failure—as voltage fell at the generator bus, the generator tried to increase its production of reactive power by increasing the excitation current – see Appendix A. This caused the generator’s excitation protection scheme to trip the plant off to protect its windings and coils from over-heating. Several of the other generators

which tripped early in the cascade came off under similar circumstances as excitation systems were overstressed to hold voltages up.

After the cascade was initiated, huge power swings across the torn transmission system and excursions of system frequency put all the units in their path through a sequence of major disturbances that shocked several units into tripping. Plant controls had actuated fast governor action on several of these to turn back the throttle, then turn it forward, only to turn it back again as some frequencies changed several times by as much as 3 Hz (about 100 times normal). Figure 15 is a plot of the MW output and frequency for one large unit that nearly survived the disruption but tripped when in-plant hydraulic control pressure limits were eventually violated. After the plant control system called for shutdown, the turbine control valves closed and the generator electrical output ramped down to a preset value before the field excitation tripped and the generator breakers opened to disconnect the unit from the system.

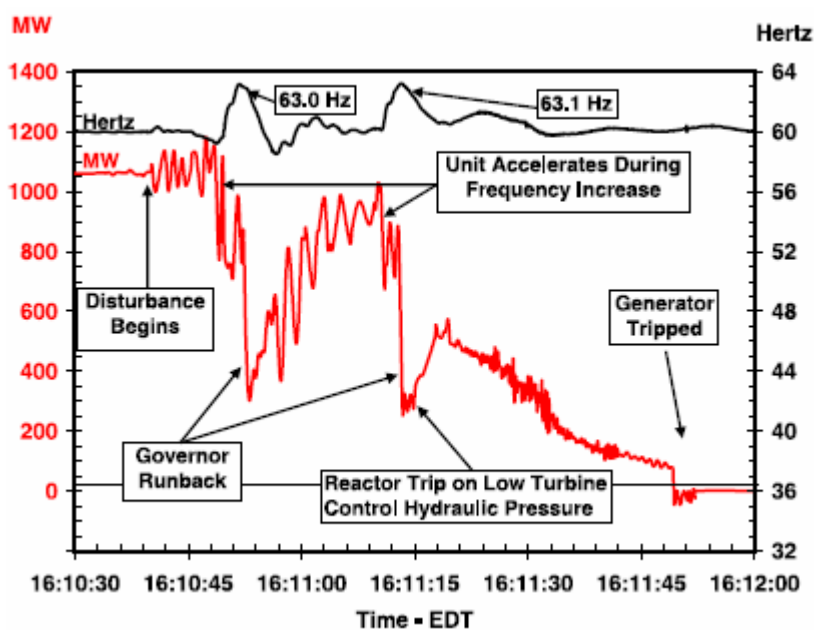

Figure 15. Events at One Large Generator During the Cascade [1].

**Plant control systems.** The second reason for power plant trips was actions or failures of plant control systems. One common cause in this category was a loss of sufficient voltage to in-plant loads. Some plants run their internal cooling and processes (house electrical load) off the generator or off small, in-house auxiliary generators, while others take their power off the main grid. When large power swings or voltage drops reached these plants in the latter category, they tripped off-line because the grid could not supply the plant's in-house power needs reliably.

**Consequential trips.** Most of the unit separations fell in the third category of consequential tripping—they tripped off-line in response to some outside condition on the grid, not because of any problem internal to the plant. Some generators became completely removed from all loads; because the fundamental operating principle of the grid is that load and generation must balance, if there was no load to be served the power plant shut down in response to over-speed and/or over-voltage protection schemes. Others were overwhelmed because they were among a few power plants within an electrical island, and were suddenly called on to serve huge customer loads, so the imbalance caused them to trip on under-frequency and/or under-voltage

protection. A few were tripped by special protection schemes that activated on excessive frequency or loss of pre-studied major transmission elements known to require large blocks of generation rejection.

#### **APPENDIX D: AUTOMATIC GENERATION CONTROL (AGC)**

According to the law of preservation of energy, energy produced in the system at any instant of time must be equal to energy consumed (i.e. the sum of energy demand, losses and energy stored). Any disturbance changing the energy balance triggers a process called primary frequency control. For example a loss of a power station causes energy deficit as demand exceeds generation. In the first instance this deficit is made up by drawing on the kinetic energy stored in all rotating masses (generators and motors) in the system. As kinetic energy is proportional to the velocity squared, velocity of all the generators drops and so does the frequency as it is proportional to velocity. As frequency is the same at any point of an interconnected system, the drop of frequency is picked up by turbine governors of all the generators in the system and the governors automatically open up turbine valves increasing power output from the generators. This process continues until, after about a minute, a new equilibrium is reached when generation is again equal to demand although at a lower frequency. All the generators must be equipped with turbine governors reacting in the described above way. Hence primary frequency control is fully automatic and all the system generators participate in it. In order for the primary frequency control to be effective, there must be enough spinning reserve in the system, i.e. a large proportion of generators must be partly loaded.

Once the primary frequency control is over and the frequency has stabilised at a lower value, it is returned to its nominal value in the process called secondary frequency control, which can be either manual or automatic. The system operator sends signals to selected power stations to increase their power output or to start up if they have not been running. As power output from those selected stations increases, frequency rises and the generators not participating in secondary frequency control scale back automatically their output to the pre-disturbance levels. This continues for several minutes until a new equilibrium is reached with the frequency returned to its nominal value and the initial power deficit covered by the selected power stations participating in secondary frequency control.

In an interconnected system, system operators monitor so called area control error (ACE), made up of the frequency error and the net tie-line interchanges errors, in order to maintain scheduled power interchanges . Further details can be found in [11, 12].

If, during any stage of frequency control, frequency drops too much indicating a large energy deficit, automatic load shedding is initiated in order to restore energy balance. Under-frequency load shedding is usually executed in a number of pre-determined stages triggered by different levels of frequency drop.

## **APPENDIX E – VOLTAGE ANGLES AND STABILITY**

In a stable power system frequency is the same at any location and all the sinusoidal voltages vary in synchronism with each other. Voltage (or phase) angle at any location is defined as the phase shift between the synchronously-rotating sinusoidal voltage at that point and an arbitrary chosen reference point (slack node).

Power flow in a line is roughly proportional to the sine of the phase shift between the terminal nodes of the line. Hence the theoretically maximum value of a power flow corresponds to the phase shift of  $90^{\circ}$ , as  $\sin 90^{\circ} = 1$ . Exceeding that value results in a loss of stability (synchronism) between two ends of the line, i.e. sinusoidal voltages will not vary synchronously with each other. In practice, loss of synchronism may occur at a lower value of phase angle.

The same holds true for areas of an interconnected power system. Two areas will lose synchronism when power transfers between the areas exceed certain maximum value corresponding to the phase shift between the centres of inertia of each area exceeding  $90^{\circ}$ .