



Intelligent Energy Management in Buildings

May 2008

Jim Wallace

Director, Home & Emerging Solutions

ARM

ARM at the Heart of Low Power Products

- ARM[®] technology lies at the heart of advanced low power digital products
- >10 billion processors shipped since 1990
 - 8 million processors per day
- The ARM Connected Community[®] is a network of more than 400 supporting companies in the embedded-electronics supply chain
- ARM supplies processor designs; our Partners make ARM Powered[®] products around them

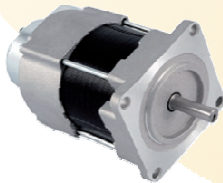

Sustainable Energy Use

- Three pillars for sustainable energy
 - Efficient transformation of primary energy to end-use energies
 - Efficient use of end-use energies
 - Use of renewable energies

- All three pillars must be developed equally!



Key Business Opportunities

- Commercial & Residential Buildings: the biggest consumer
 - Consume over 40% of total energy*
 - Key areas : HVAC, lighting, Refrigeration
- But...
 - Consumer electronics (CE) will account for 45% of domestic electricity usage by 2020**
 - electronics must become more efficient!
- Industry: also a key target
 - Motors consume 60% of electricity usage***

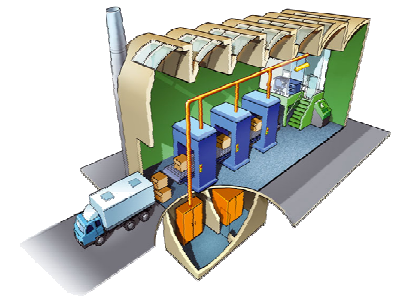
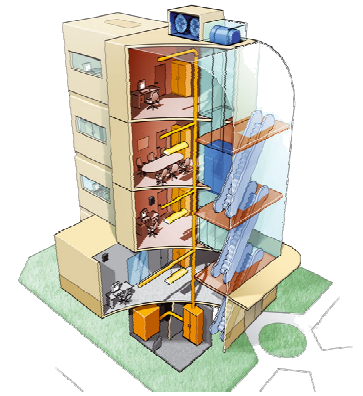

* United States Department of Energy: Energy consumption by application in commercial buildings

** The ampere strikes back - Energy Saving Trust June 2007

*** Energy Use in North America - US Department of Energy

Key Business Opportunities



Over three years, the power bill for a single server can be higher than the cost of the computer itself.

*Dave Douglas
Vice President of Eco Responsibility
Sun Microsystems*

Move to New Low Power Intelligence

- *Old habits + old technology*
= predictable consequences
- *Old habits + new technology*
= dramatically altered consequences

Al Gore, "An Inconvenient Truth"

Trending Towards Energy Efficiency

The EPA's Energy Star 4.0 regulations, which took effect on July 20, 2007, require PC manufacturers to convert 80 percent of incoming electricity into usable computer power in order to be declared "energy efficient".



1879



Low Power Variable Speed Motors

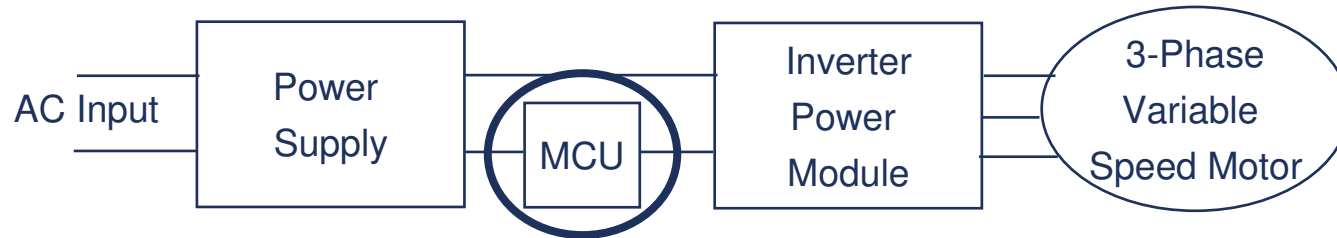

- Most US home appliance motors have been driven by inefficient electromechanical control systems, using up over 50% of electricity*
 - Major home appliances: refrigerators, washers & dryers, vacuum cleaners, air conditioners, gas boilers, dishwashers, pool pumps, etc.
- Electronic variable-speed controllers, using 32-bit processors and IPM (Inverter or Intelligent Power Module) could save up to 60% of the energy consumed*
 - Adding intelligence to motors in industrial and household appliances requires accurate system development using graphical languages from companies such as National Instruments to model software design from algorithm to implementation

* Sanken – Sept 2007, Energy Use in North America (US Department of Energy)



Connected Home Entertainment System

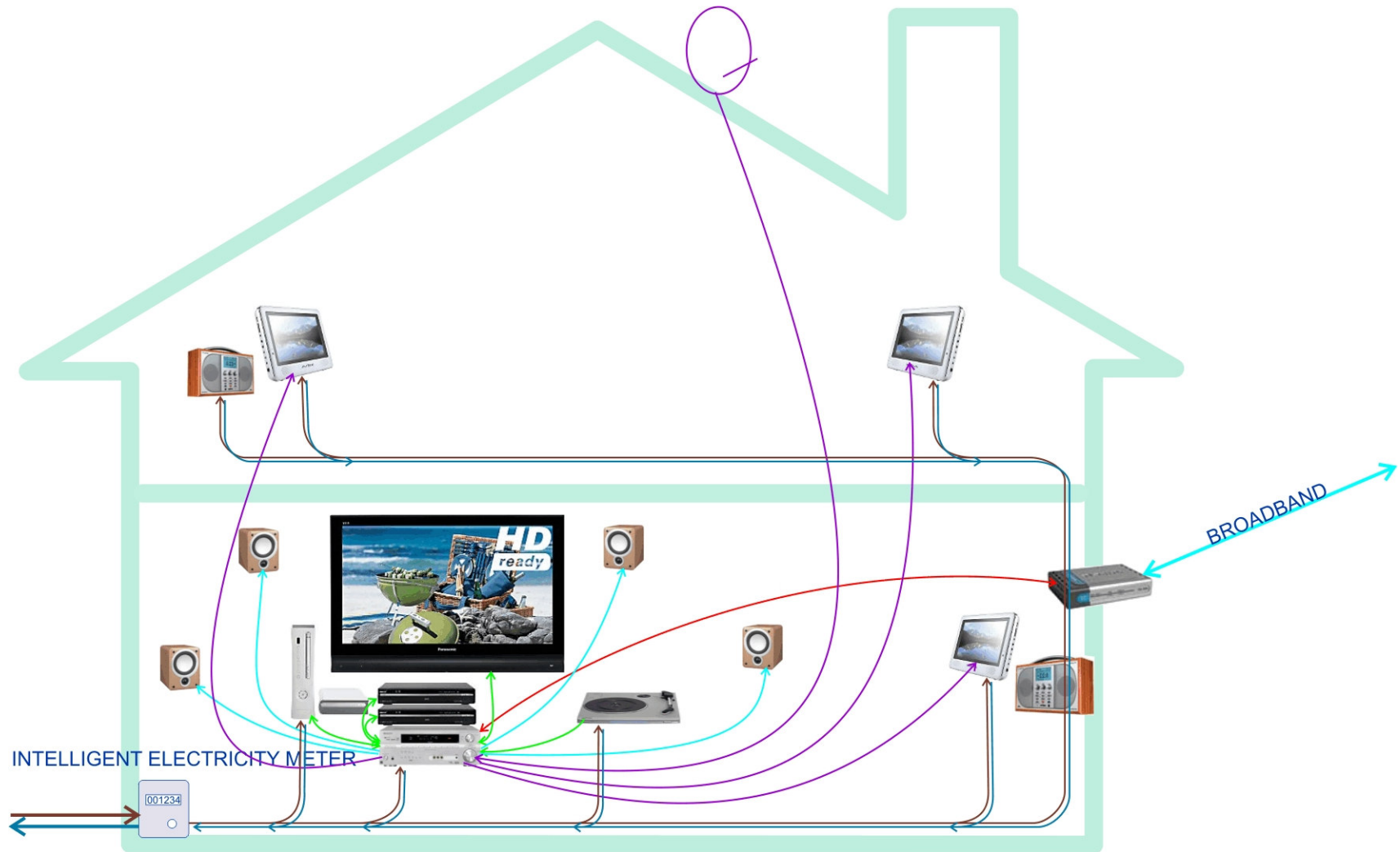

Connected Appliance System

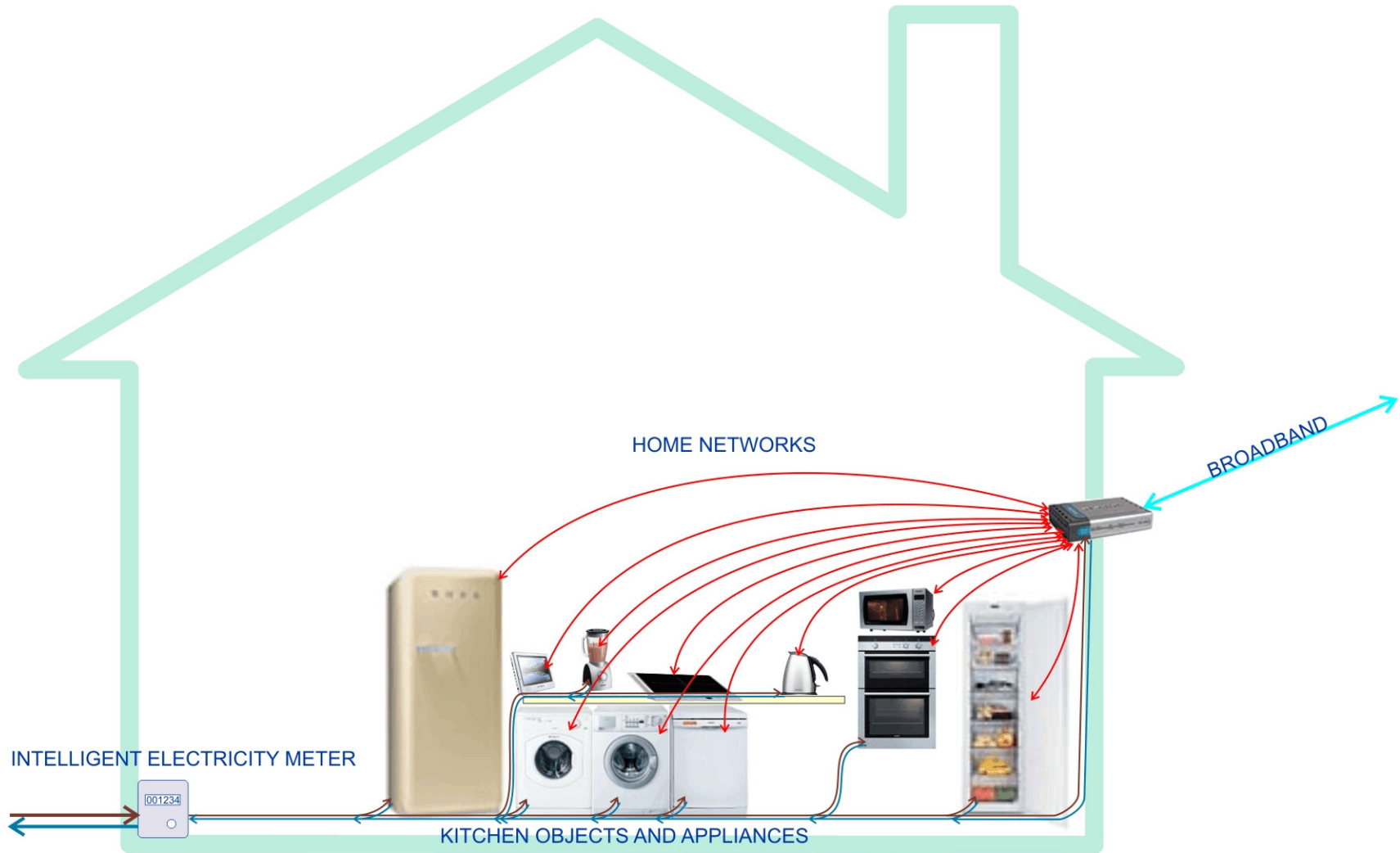

Connected Security System

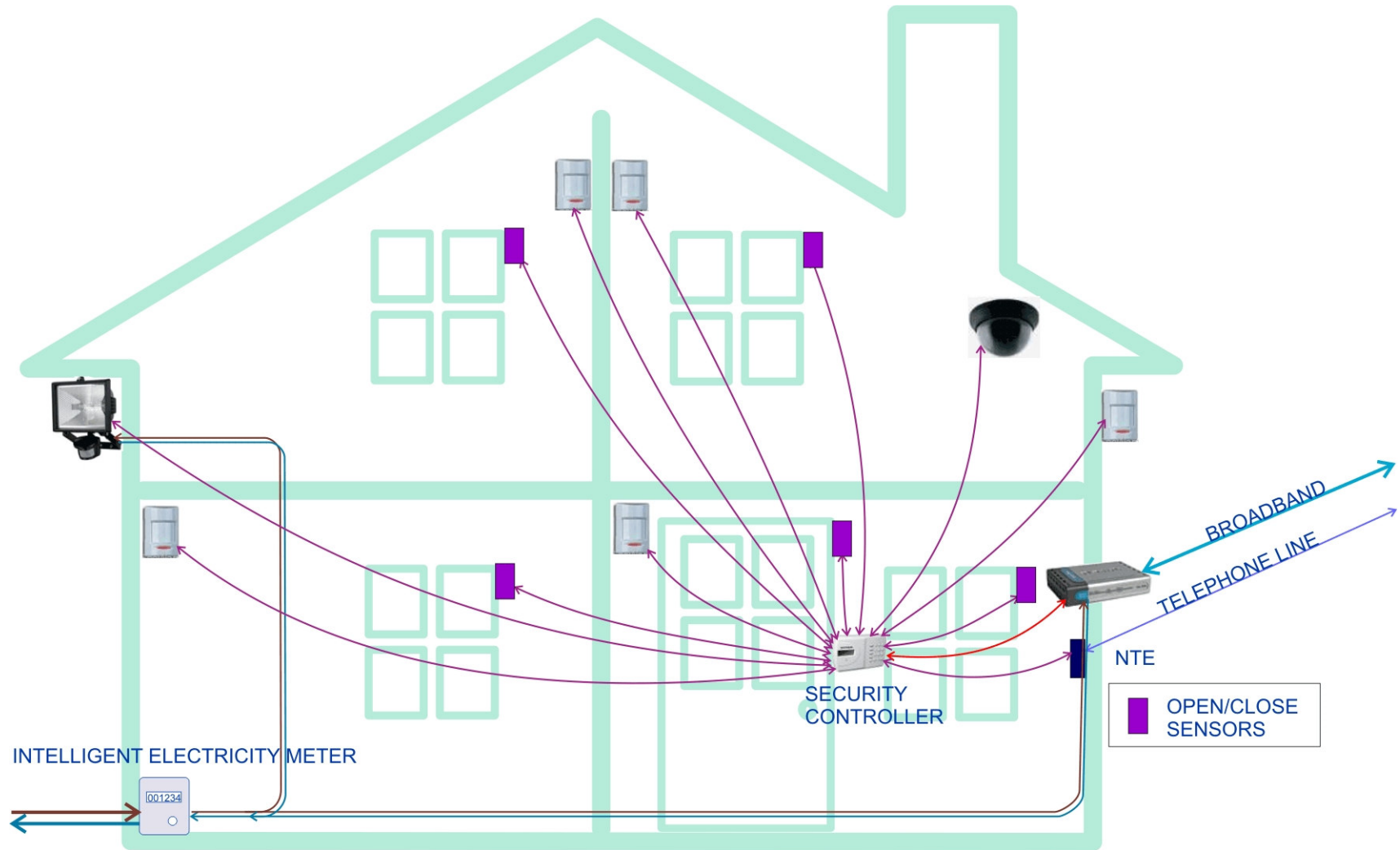

Connected Home Healthcare System

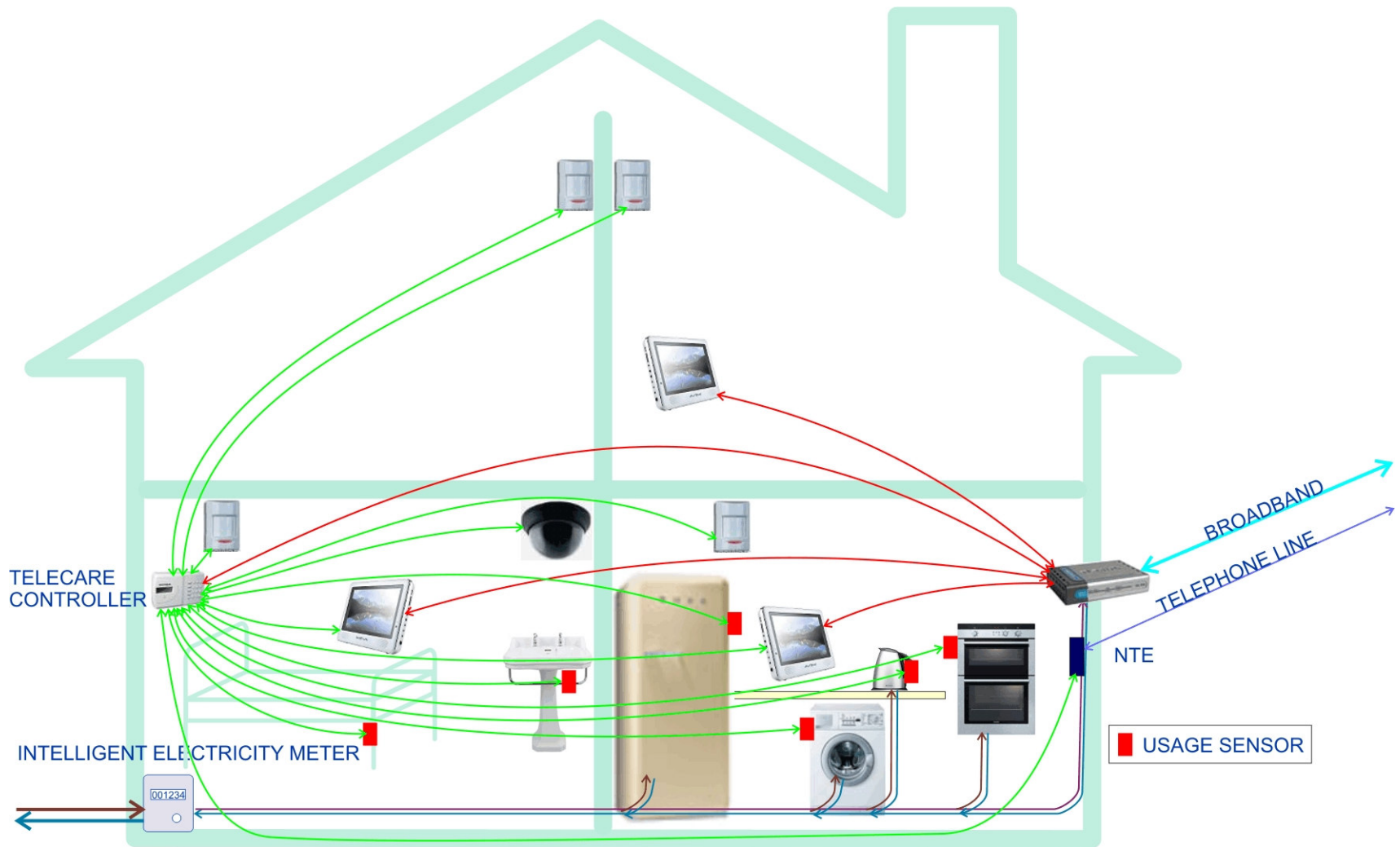

The Intelligent Home – Energy Management

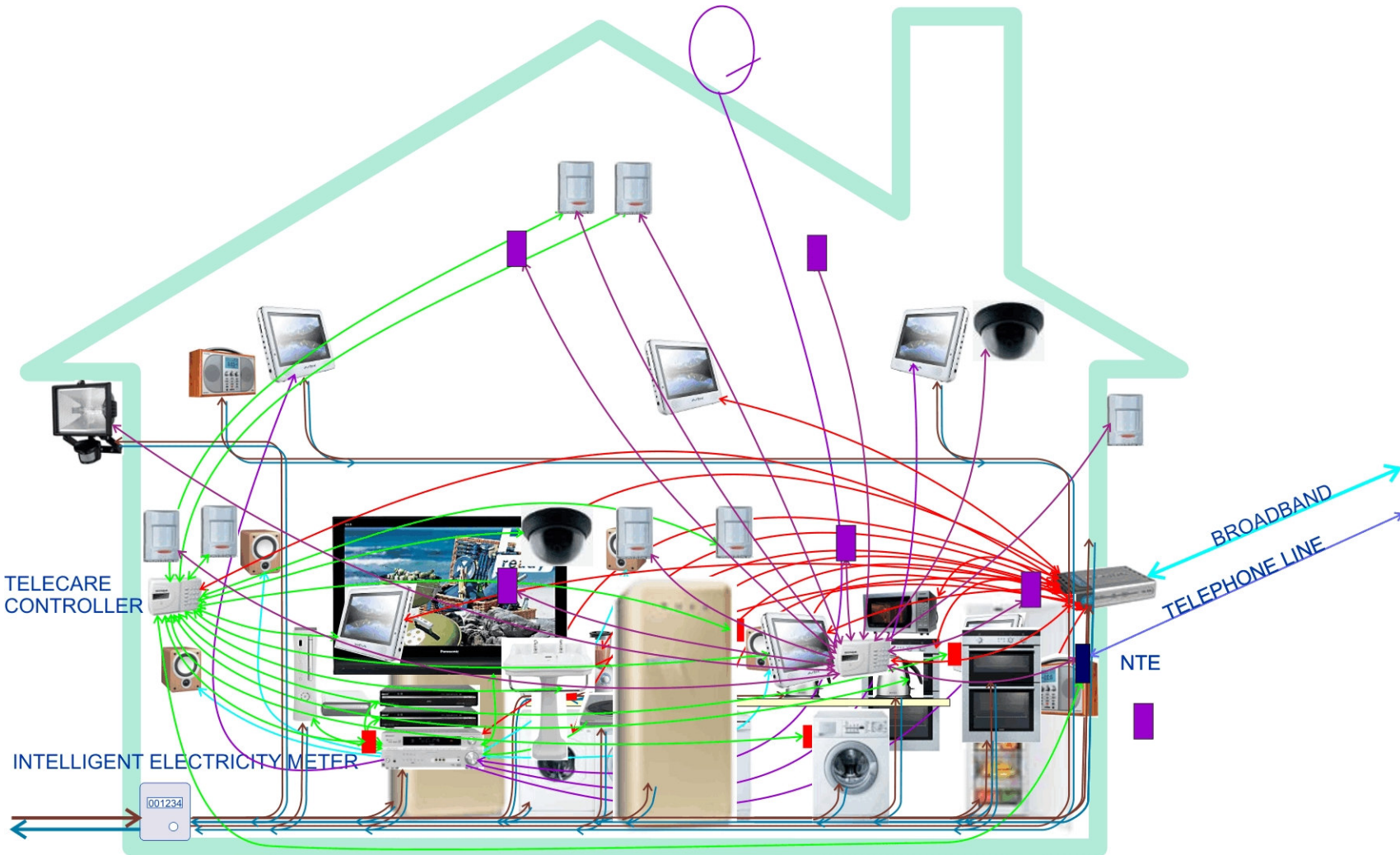

Intelligent Control of Dynamic Systems

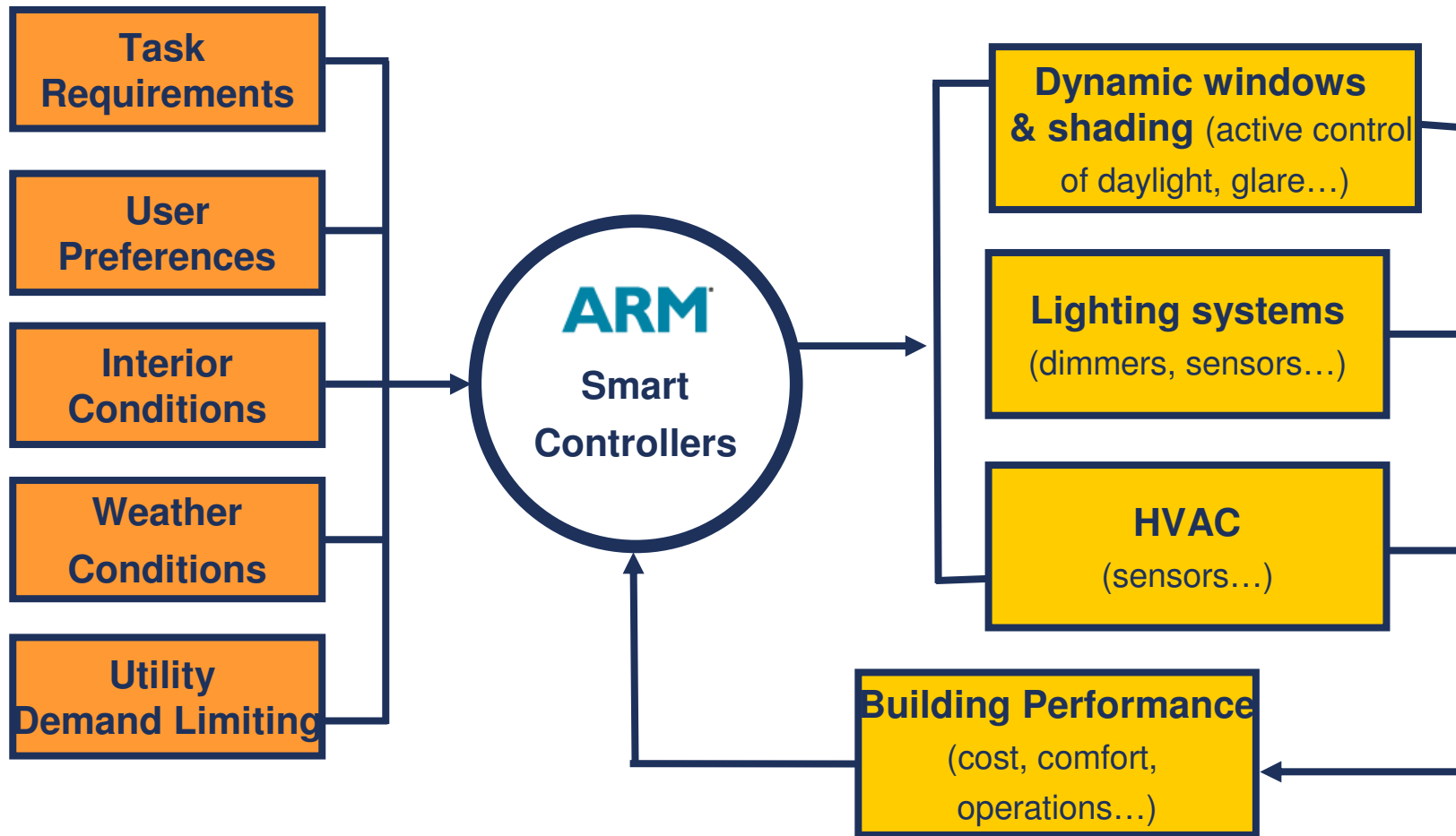

- Tomorrow's energy efficient building will require additional processing power at all levels of its infrastructure

Battery-Free Wireless Sensors & Actuators

- Most wireless sensor nodes presently powered by batteries
 - Battery replacement is costly
 - Self-powered sensors and actuators offer maintenance-free lifecycles and are environment-friendly
- Alternative power sources are being developed
 - Solar, vibration, rotation, temperature, organic material...
 - May use a capacitor as a buffer when system not in use
- ARM low power technology complements these developments and provides low power intelligence

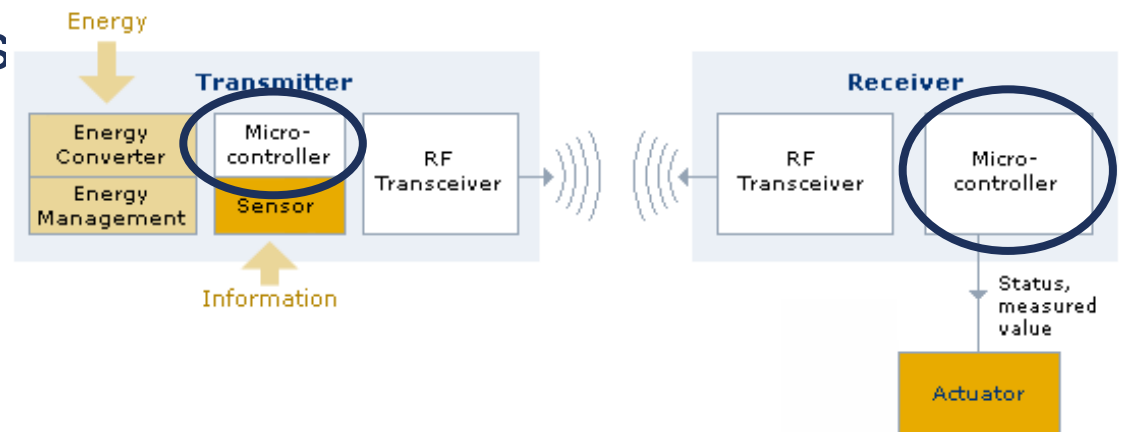

Home Entertainment - the Complex STB

- Greater functionality can require more power
- More tuners
- Home networking connectivity
 - Set Top Boxes (STBs) active on multiple networks
 - Multi-stream DCAS / DRM
- Increased decode capability
- Need high-performance, low power processing!

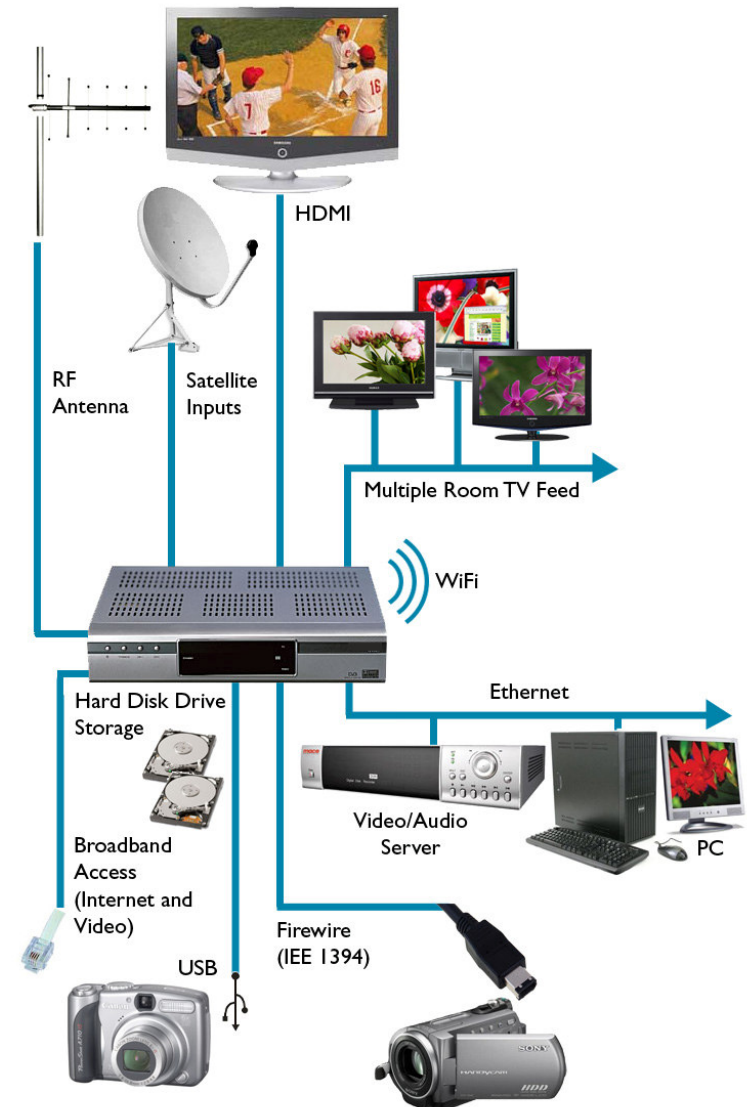

3 Areas For Possible Efficiency Gains

- The system on chip (SoC)
 - By copying technology used in mobile phones, ARM Powered[®] STBs could reduce standby power to < 1W
 - Will require cooperation from everyone in the development and deployment chain
- The client software that runs on the STB
 - Powering down tuners when not in use
 - Powering down blocks within SoC when not in use
- The networks that are connected to the STB
 - Monitoring presence
 - Powering down home connectivity when not in use
 - Minimizing the frequency of communications / pings

Something Must Change!

Improving power efficiency during usage as well as during standby

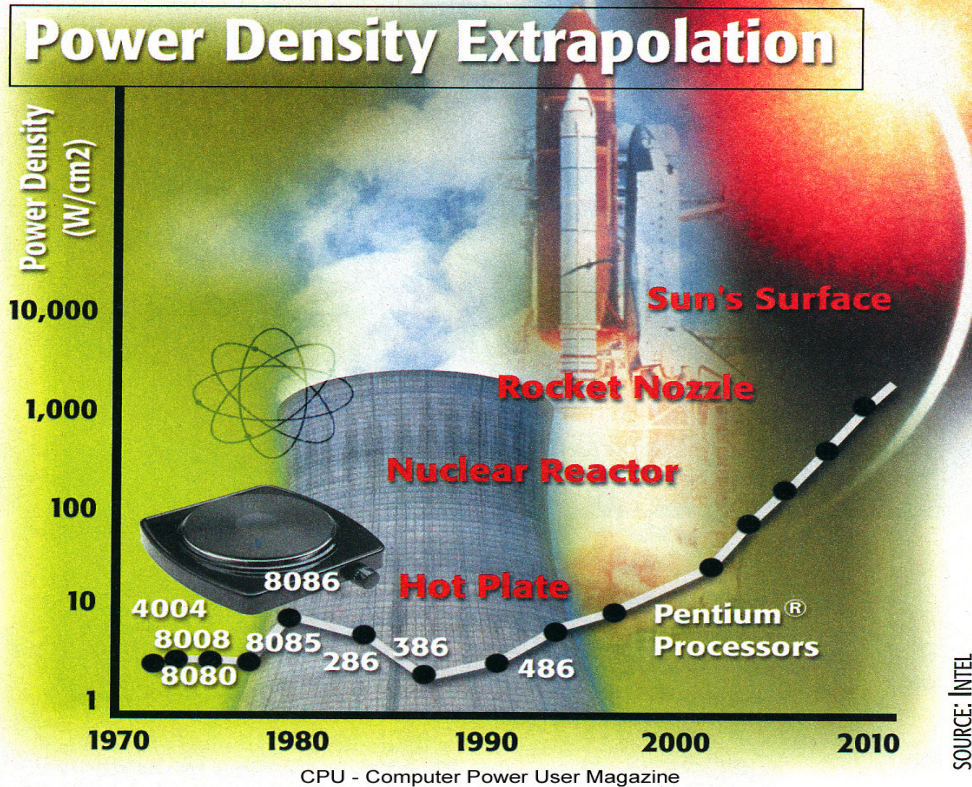

Investing in Multiprocessing

- ARM was first in multiprocessing
- Multiprocessing offers the flexibility of both high performance and low power
 - Many ARM processor-based SoCs today already have multiple processors
 - ARM11™ MPCore™ multicore processor has more than ten licensees developing chips for printers, HDTV, DSC, networking, and more
- New ARM Cortex™-A9 further enhances MPCore technology

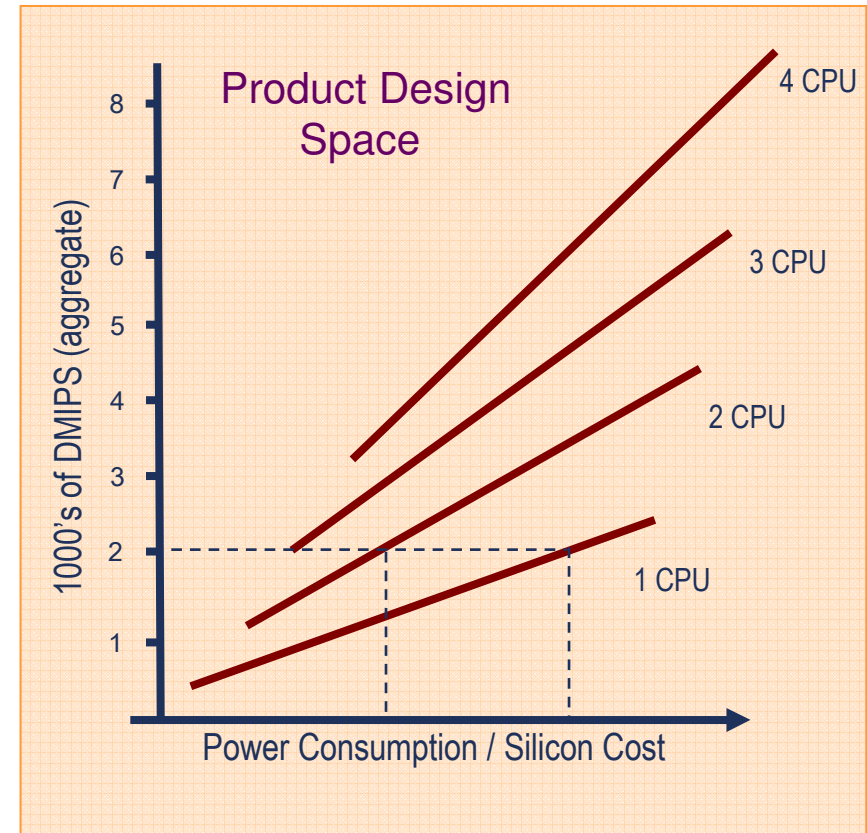

Power Management Techniques

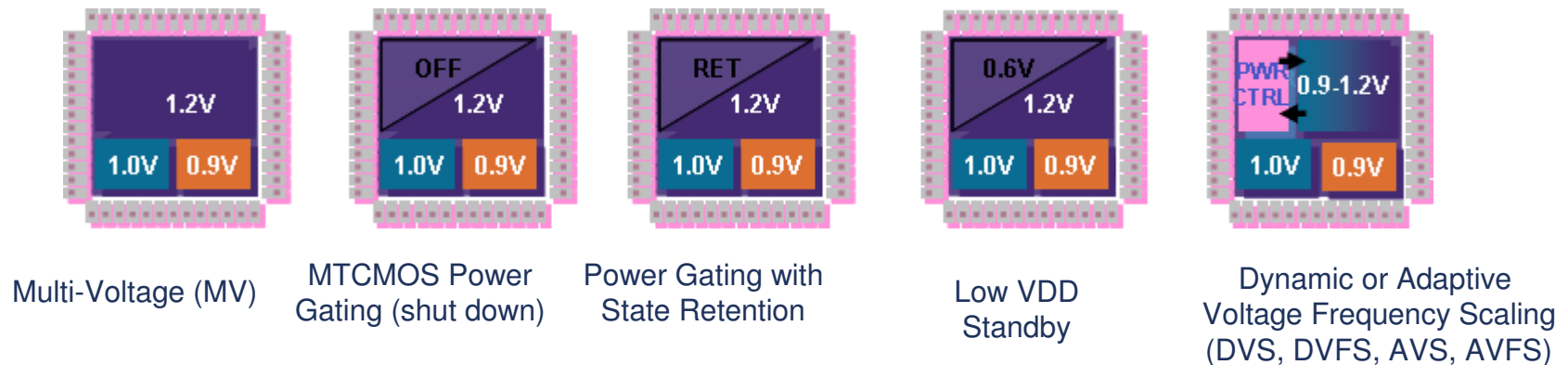
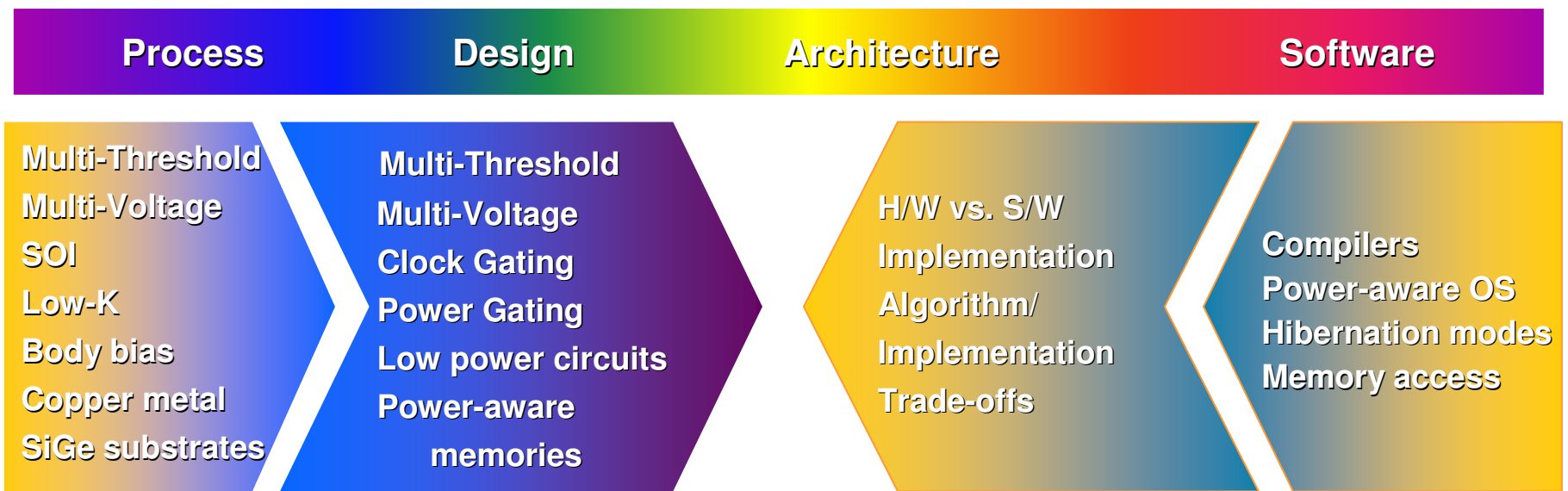

Can result in > 2x savings in dynamic power
and 10x reduction in leakage power

Low Power ARM Products

Cortex-A9 MPCore Processor Structure

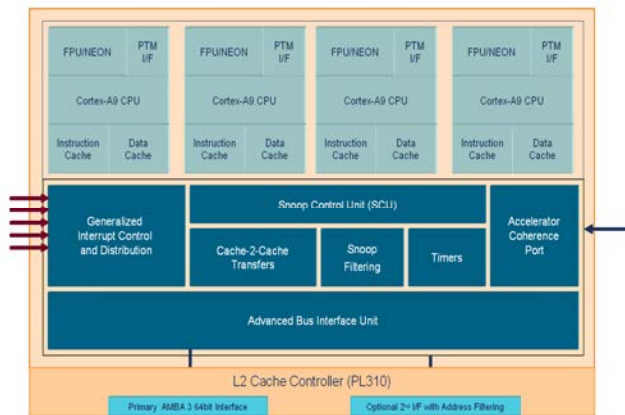

ARM Cortex™ Processors

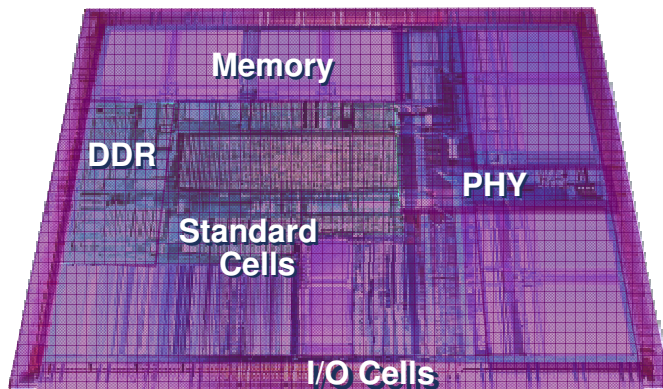

ARM Artisan® Libraries and Power Management Kit (PMK)

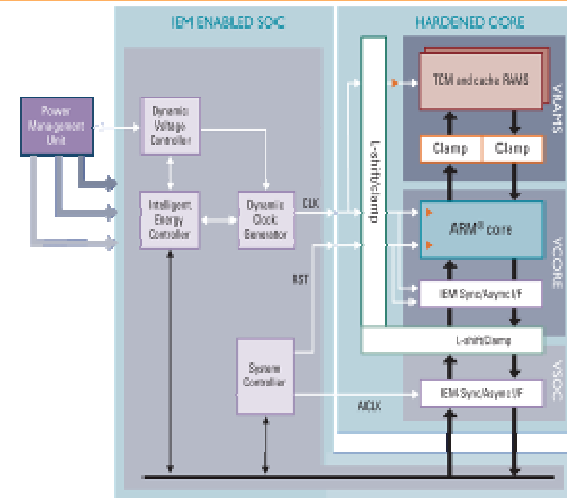

Intelligent Energy Manager (IEM™) DVFS technology

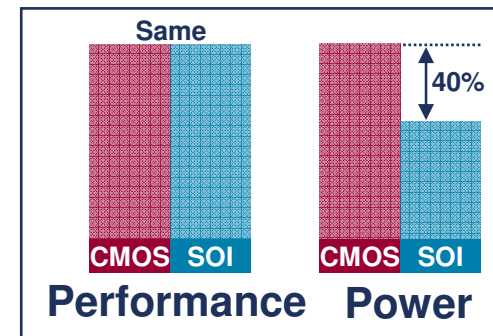

Silicon-On-Insulator Libraries and Memories

Texas Instruments - OMAP

	OMAP	OMAP 2	OMAP 3
Process Technology	130nm → 90nm	90nm → 65nm	65nm → 45nm
ARM Core	926 v5	1136 v6	Cortex A8 v7
Power per Task		Up to 40% less than OMAP	Up to 30% less than OMAP 2
Multimedia Accelerator	DSP 55x™	DSP 55x™+ IVA 2D/3D hardware	IVA 2+ 2D/3D hardware
Display	QVGA	VGA	XGA
Camera	2 megapixel	6 megapixel	12 megapixel
Video Playback	QVGA	VGA → DVD	DVD → HD
Video Camcorder	QVGA	VGA → DVD	DVD
Video-conferencing	QCIF	CIF	VGA

- Exhaustive use of power and performance management technologies
 - Intelligent and adaptive hardware and software techniques that dynamically control voltage and frequency based on device activity, modes of operation and temperature



Enabling Low Power Through Partners

- NXP(Conexant) SoCs for high-end dual TV and gateway set top boxes
 - Multi-room viewing, watch and record on two separate TVs from a single set top box
- Low power ARM11 and ARM9™ families at the heart of SoCs
- Chips in use in DirecTV, DISH Network and Sky boxes

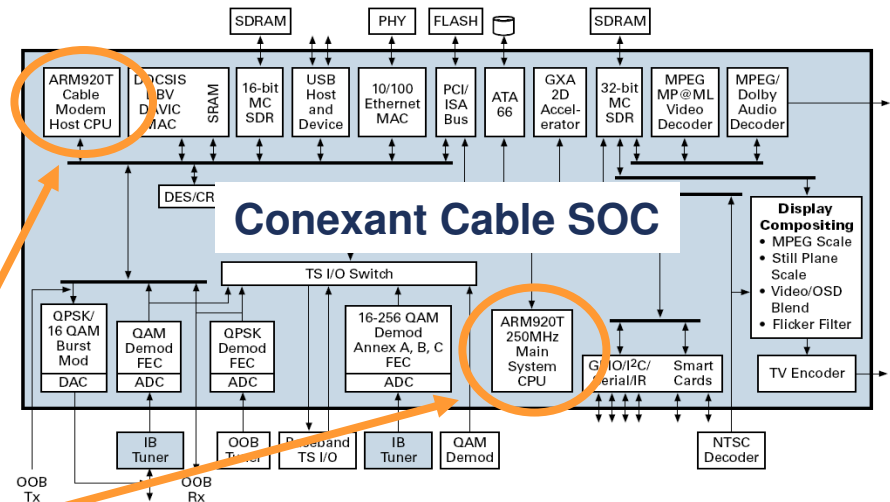

CO₂ savings of
32,000 tonnes

Auto-Standby

ARM Enables Low Power TV: Vizio

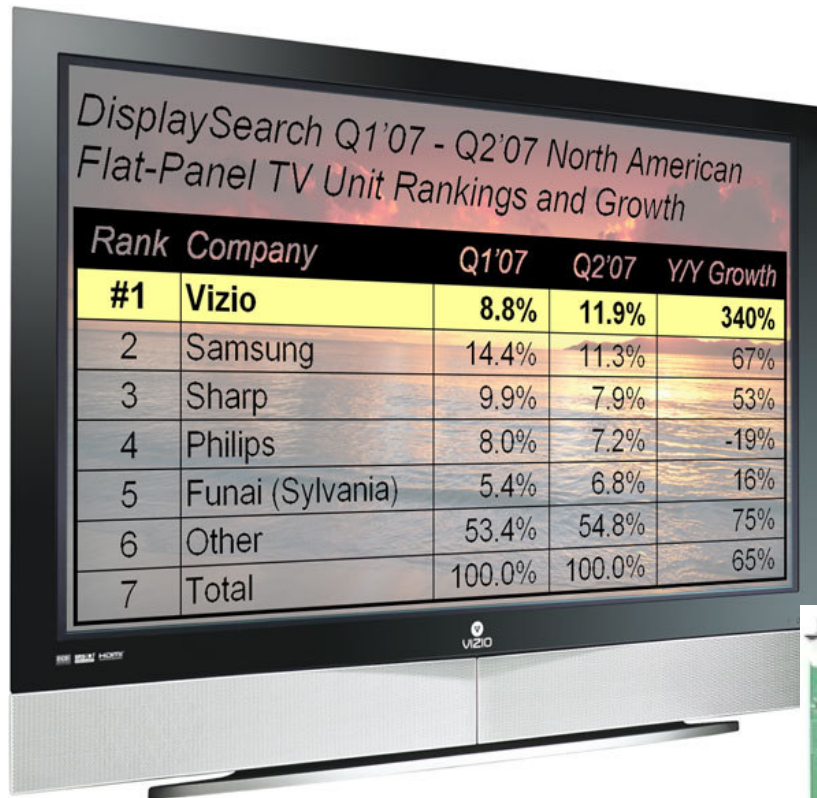

iSuppli Teardown Report
Vizio 40-inch DTV
(Mediatek/ARM Chip)

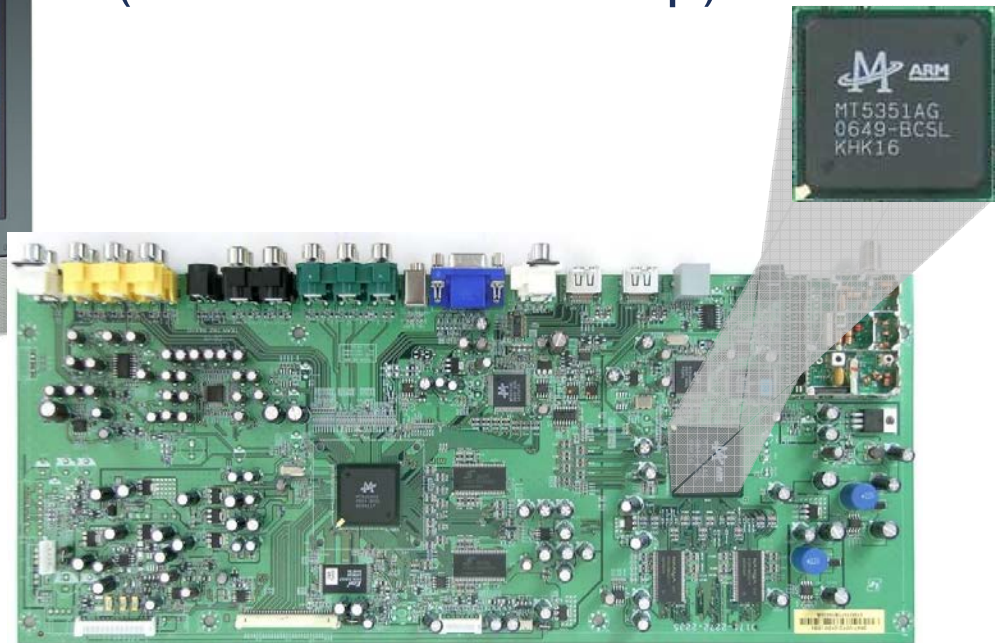

The Opportunity

- ARM can make a difference across a whole range of CE products, intelligently managing energy efficiency across a range of performance points:
 - Energy efficient 32-bit processor performance, from the ARM Cortex™-M3 to the multicore Cortex-A9
 - Low power Metro™ libraries
 - Intelligent Energy Management and Power Management Kits
 - Tools and software that seamlessly work together
 - Additionally, we leverage our Connected Community to provide complete low power solutions for products based on the ARM architecture and hence reduce emissions produced by our customers' products

